

Strictly Confidential — (For Internal and Restricted Use Only)

Secondary School Certificate Examination

March 2017

Marking Scheme — Mathematics 30/2/1, 30/2/2, 30/2/3 (Foreign)

General Instructions:

1. The Marking Scheme provides general guidelines to reduce subjectivity in the marking. The answers given in the Marking Scheme are suggested answers. The content is thus indicative. If a student has given any other answer which is different from the one given in the Marking Scheme, but conveys the meaning, such answers should be given full weightage
2. Evaluation is to be done as per instructions provided in the marking scheme. It should not be done according to one's own interpretation or any other consideration — Marking Scheme should be strictly adhered to and religiously followed.
3. Alternative methods are accepted. Proportional marks are to be awarded.
4. If a candidate has attempted an extra question, marks obtained in the question attempted first should be retained and the other answer should be scored out.
5. A full scale of marks - 0 to 90 has to be used. Please do not hesitate to award full marks if the answer deserves it.
6. Separate Marking Scheme for all the three sets has been given.
7. As per orders of the Hon'ble Supreme Court. The candidates would now be permitted to obtain photocopy of the Answer book on request on payment of the prescribed fee. All examiners/Head Examiners are once again reminded that they must ensure that evaluation is carried out strictly as per value points for each answer as given in the Marking Scheme.

QUESTION PAPER CODE 30/2/1
EXPECTED ANSWER/VALUE POINTS

SECTION A

1. $6x^2 - x - k = 0$

$$6\left(\frac{2}{3}\right)^2 - \left(\frac{2}{3}\right) - k = 0$$

$\frac{1}{2}$

$k = 2$

$\frac{1}{2}$

2.

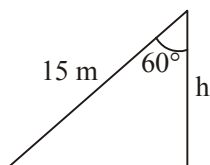

$$\cos 60^\circ = \frac{h}{15}$$

$\frac{1}{2}$

$h = 7.5 \text{ m}$

$\frac{1}{2}$

3. No. of cubes = $\frac{9 \times 8 \times 2}{2 \times 2 \times 2}$

$\frac{1}{2}$

= 18

$\frac{1}{2}$

4.

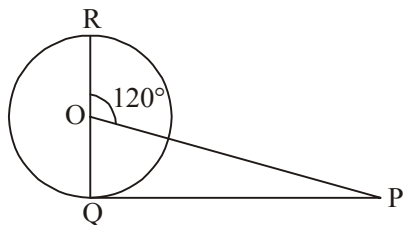

$$\angle POR = \angle OQP + \angle OPQ$$

$$\angle OPQ = 120^\circ - 90^\circ$$

$\frac{1}{2}$

= 30°

$\frac{1}{2}$

SECTION B

5. $\sqrt{3}x^2 + 10x - 8\sqrt{3} = 0$

$$\sqrt{3}x^2 + 12x - 2x - 8\sqrt{3} = 0$$

$\frac{1}{2}$

$$\sqrt{3}x(x + 4\sqrt{3}) - 2(x + 4\sqrt{3}) = 0$$

$\frac{1}{2}$

$$(\sqrt{3}x - 2)(x + 4\sqrt{3}) = 0$$

$\frac{1}{2}$

$$x = \frac{2}{\sqrt{3}}, -4\sqrt{3}$$

$\frac{1}{2}$

6. $7a_7 = 11a_{11}$

$$7(a + 6d) = 11(a + 10d)$$

$\frac{1}{2}$

$$7a - 11a + 12d - 110d = 0$$

$\frac{1}{2}$

$$-4a - 68d = 0$$

$$a + 17d = 0$$

$\frac{1}{2}$

$$a_{18} = 0$$

$\frac{1}{2}$

7. Total number of outcomes = 36

$\frac{1}{2}$

$$P(\text{Product appears is less than 18}) = \frac{26}{36} = \frac{13}{18}$$

$1\frac{1}{2}$

8.

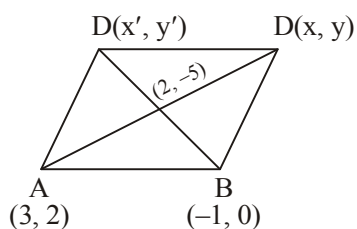

Let other two coordinates are

(x, y) and (x', y')

$$2 = \frac{x + 3}{2}$$

$$\Rightarrow x = 1$$

$\frac{1}{2}$

$$\text{and, } -5 = \frac{2 + y}{2}$$

$$y = -12$$

$\frac{1}{2}$

$$\text{Again, } \frac{-1 + x'}{2} = 2$$

$$x' = 5$$

$\frac{1}{2}$

$$\text{and } \frac{0 + y'}{2} = -5$$

$$y' = -10$$

$\frac{1}{2}$

Hence co-ordinates are $(1, -12)$ and $(5, -10)$

(2)

30/2/1

9. $AB = AC$ (Given)

$AD = AF$ (tangents from external point)

$\frac{1}{2}$

On subtracting,

$BD = CF$

$BD = BE$ (tangents from external point)

1

and $CF = EC$

$\Rightarrow BE = EC$

10. In leap year = 52 weeks + 2 days

$\frac{1}{2}$

Two days may be, (M, Tu), (Tu, W), (W, Th), (Th, F), (F, Sat)

(Sat, Sun), (Sun, M)

1

Required probability = $\frac{2}{7}$

$\frac{1}{2}$

SECTION C

11. For equal roots

$D = 0$

$(b - c)^2 - 4(a - b)(c - a) = 0$

1

$b^2 + c^2 - 2bc - 4ac + 4a^2 + 4bc - 4ab = 0$

$(b + c - 2a)^2 = 0$

$1 \frac{1}{2}$

$\Rightarrow 2a = b + c$

$\frac{1}{2}$

12. The series can be rewritten as,

$(5 + 9 + 13 + \dots + 81) + (-41 + (-39) + (-39) + \dots + (-5) + (-3))$

$\frac{1}{2}$

for $5 + 9 + 13 + \dots 81$

$a = 5$

$d = 4$

$$a_n = 81$$

$$5 + (n - 1)4 = 81$$

$$\Rightarrow n = 20$$

$$S_n = \frac{20}{2}(5 + 81) = 860$$

$$\frac{1}{2}$$

for $(-41) + (-39) + (-37) \dots + (-5) + (-3)$

$$a = -41$$

$$d = 2$$

$$a_n = -3$$

$$-41 + (n - 1)2 = -3$$

$$n = 20$$

$$\frac{1}{2}$$

$$S_n = \frac{20}{2}(-41 - 3) = -440$$

$$\frac{1}{2}$$

Sum of series = $860 - 440$

$$= 420$$

$$\frac{1}{2}$$

13.

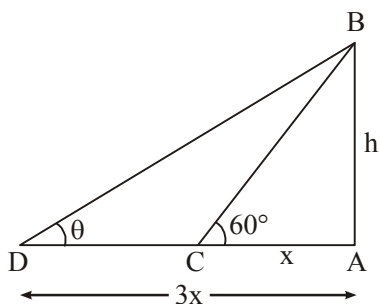

Correct Figure $\frac{1}{2}$

$$\tan 60^\circ = \frac{h}{x}$$

$$1$$

$$h = \sqrt{3}x$$

$$\tan \theta = \frac{h}{3x}$$

$$\tan \theta = \frac{\sqrt{3}x}{3x}$$

$$\tan \theta = \frac{1}{\sqrt{3}}$$

$$1$$

$$\Rightarrow \theta = 30^\circ$$

$$\frac{1}{2}$$

(4)

30/2/1

14.

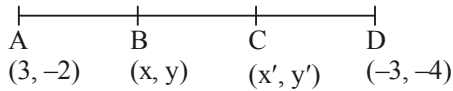

Let the co-ordinates be (x, y) and (x', y')

$$x = \frac{1(-3) + 2(3)}{1 + 2} = 1$$

$$y = \frac{1(-4) + 2(-2)}{1 + 2} = \frac{-8}{3} \quad 1 \frac{1}{2}$$

$$x' = \frac{2(-3) + 1(3)}{1 + 2} = -1$$

$$y' = \frac{2(-4) + 1(-2)}{1 + 2} = \frac{-10}{3} \quad 1 \frac{1}{2}$$

15. PA = PB = 4 cm (tangents from external point)

$\frac{1}{2}$

$$\angle PAB = 180^\circ - 135^\circ$$

$$= 45^\circ$$

$\frac{1}{2}$

$$\angle APB = 180^\circ - 45^\circ - 45^\circ$$

$$= 90^\circ$$

$\frac{1}{2}$

$\Rightarrow \triangle ABP$ is a isosceles right angled triangle

$$\Rightarrow AB^2 = 2AP^2$$

$$= 2(4)^2 = 32$$

1

$$AB = 4\sqrt{2} \text{ cm}$$

$\frac{1}{2}$

16.

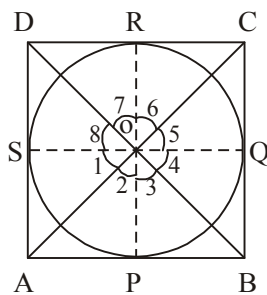

$$\triangle AOS \cong \triangle AOP$$

$$\Rightarrow \angle 1 = \angle 2$$

1

$$\text{Similarly } \angle 4 = \angle 3$$

$$\angle 5 = \angle 6$$

$$\angle 8 = \angle 7$$

$$\Rightarrow (\angle 1 + \angle 8) + (\angle 4 + \angle 5) = (\angle 2 + \angle 3) + (\angle 6 + \angle 7) = 180^\circ \quad 1$$

$$\Rightarrow \angle AOD + \angle BOC = 180^\circ$$

$$\text{and } \angle AOB + \angle COD = 180^\circ$$

1

17. 3 marks be given to every attempt

3

18. $r : h = 5 : 12$

$$\text{Let } r = 5x$$

$$h = 12x$$

$$\text{Volume} = \frac{1}{3} \pi r^2 h$$

$$314 = \frac{1}{3} \times 3.14 (5x)^2 \times 12x$$

$$\Rightarrow x = 1$$

$$r = 5 \text{ cm}$$

$$h = 12 \text{ cm}$$

$$l = \sqrt{(12)^2 + (5)^2} = 13 \text{ cm}$$

$$\text{TSA} = \pi r(l + r) = 3.14 \times 5 (13 + 5)$$

$$= 282.6 \text{ cm}^2$$

1

1

1

19. Co-ordinates of B are (5, 0)

Let co-ordinates of C be (x, y)

$$AC^2 = BC^2$$

$$(x - 2)^2 + (y - 0)^2 = (x - 5)^2 + (y - 0)^2$$

$$x^2 + 4 - 4x + y^2 = x^2 + 25 - 10x + y^2$$

$$6x = 21$$

$$x = \frac{7}{2}$$

$$(x - 2)^2 + (y - 0)^2 = 9$$

$$\left(\frac{7}{2} - 2\right)^2 + y^2 = 9$$

$$y^2 = 9 - \frac{9}{4}$$

1

1

$$y^2 = \frac{27}{4}$$

$$y = \frac{3\sqrt{3}}{2} \text{ (+ve sign to be taken), Co-ordinate of C } \left(\frac{7}{2}, \frac{3\sqrt{3}}{2} \right) \quad 1$$

20. $AB = \sqrt{(-2+0)^2 + (0-2)^2} = 2\sqrt{2}$ units

$$BC = \sqrt{(0-2)^2 + (2-2)^2} = 2\sqrt{2}$$
 units

$$CA = \sqrt{(2+2)^2 + (0-0)^2} = 4$$
 units 1

$$DE = \sqrt{(-4+0)^2 + (0-4)^2} = 4\sqrt{2}$$
 units

$$EF = \sqrt{(0-4)^2 + (4-0)^2} = 4\sqrt{2}$$
 units

$$DF = \sqrt{(-4-4)^2 + (0-2)^2} = 8$$
 units 1

$$\frac{AB}{DE} = \frac{BC}{EF} = \frac{AC}{DF} = \frac{1}{2}$$

$$\therefore \triangle ABC \sim \triangle DEF \quad 1$$

SECTION D

21.

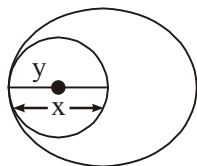

Let radii of circles be x, y ($x > y$)

$$x - y = 6 \quad \dots(1) \quad 1$$

$$\text{and } \pi x^2 + \pi y^2 = 116\pi$$

$$x^2 + y^2 = 116 \quad \frac{1}{2}$$

$$x^2 + (x - 6)^2 = 116$$

$$\Rightarrow x^2 + x^2 + 36 - 12x = 116$$

$$\Rightarrow x^2 - 6x - 40 = 0 \quad 1$$

$$(x - 10)(x + 4) = 0 \quad 1$$

$$\Rightarrow x = 10 \text{ cm (rejecting -ve value)} \quad \frac{1}{2}$$

$$\text{and } y = 4 \text{ cm}$$

22. $1 + 4 + 7 + 10 + \dots + x = 287$

$S_n = 287$

$\frac{n}{2}(2 + (n - 1)3) = 287$

$\Rightarrow 3n^2 - n - 574 = 0$

$\Rightarrow 3n^2 - 42n + 41n - 574 = 0$

$\Rightarrow (3n + 41)(n - 14) = 0$

$\Rightarrow n = 14$

$x = a + 13d = 40$

$1\frac{1}{2}$

$1\frac{1}{2}$

1

23. For constructing correct concentric circle

1

For constructing correct pair of tangents

3

24.

Correct Figure

1

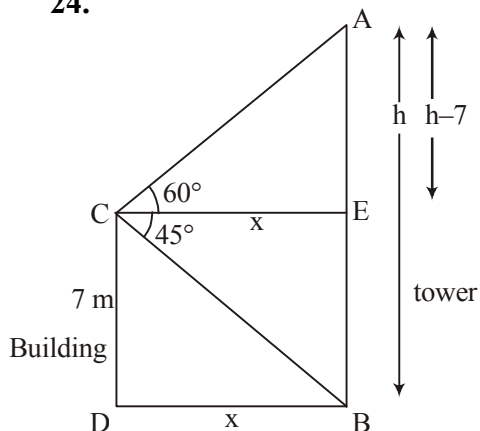

$\tan 45^\circ = \frac{7}{x}$

$x = 7$

$\tan 60^\circ = \frac{h - 7}{x}$

$7\sqrt{3} = h - 7$

$h = 7(\sqrt{3} + 1)$

$= 7(1.732 + 1)$

$= 19.124 \text{ m}$

1

1

1

25. (i) $P(\text{bears two digit number}) = \frac{81}{90}$ or $\frac{9}{10}$

2

(ii) $P(\text{a number divisible by 5}) = \frac{18}{90}$ or $\frac{1}{5}$

2

26. Let height of embankment be h mts

$17(1.5)2 \times 14 = \pi[(6.5)^2 - (1.5)^2] \times 2$

2

$2.25 \times 14 = 5 \times 8 \times h$

1

$\Rightarrow h = 0.7875 \text{ m}$

1

27. For correct given, To prove, construction, figure

$$4 \times \frac{1}{2} = 2$$

for correct proof

2

28.

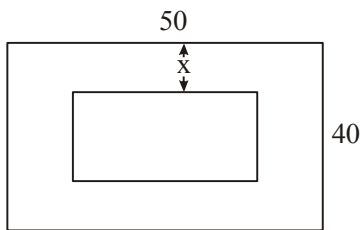

Let width of grass strip be x mts.

area of park – area of pond = 1184

$$(50 \times 40) - (50 - 2x)(40 - 2x) = 1184$$

1

$$2000 - 2000 + 180x - 4x^2 = 1184$$

$$x^2 - 45x + 296 = 0$$

1

$$x^2 - 37x - 8x + 296 = 0$$

$$x = 8, 37 \text{ (rejected)}$$

1

$$\text{Length of pond} = 50 - 16 = 34 \text{ m}$$

$$\text{Breadth of pond} = 40 - 16 = 24 \text{ m}$$

1

29.

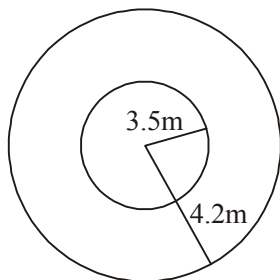

$$r_1 = 3.5\text{m}, r_2 = 4.2 \text{ m}$$

$\frac{1}{2}$

$$\text{area of path} = \pi(4.2)^2 - \pi(3.5)^2$$

1

$$= \pi[(7.7) \times 0.7]$$

$$= \frac{22}{7} \times 7.7 \times 0.7$$

$$= 16.94 \text{ m}^2$$

$1\frac{1}{2}$

$$\text{Cost of cementing the path} = 16.94 \times 110$$

$$= ₹ 1863.40$$

1

30.

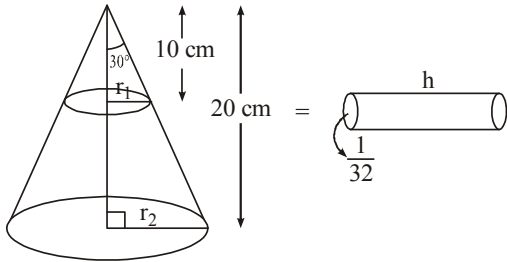

$$\tan 30^\circ = \frac{r_1}{10}$$

$$r_1 = \frac{10}{\sqrt{3}}$$

1

$$\tan 30^\circ = \frac{r_2}{20}$$

$$r_2 = \frac{20}{\sqrt{3}}$$

1

$$\frac{1}{3}\pi \times 10 \left(\left(\frac{10}{\sqrt{3}} \right)^2 + \left(\frac{20}{\sqrt{3}} \right)^2 + \frac{200}{3} \right) = \pi \left(\frac{1}{32} \right)^2 \times h$$

1

$$\frac{1}{3} \times 10 \times \frac{700}{3} \times 32 \times 32 = h$$

$$\Rightarrow h = 796444.4 \text{ cm}$$

1

or

$$7964.44 \text{ m}$$

31. Total saving = $190 \times 5 = ₹ 950$

1

The series $5 + 10 + 20 + \dots$

$$S_n = 950$$

$$\frac{n}{2}(2(5) + (n-1)5) = 950$$

1

$$n(2 + (n-1)) = 380$$

$$n^2 + n - 380 = 0$$

$$n^2 + 20n - 19n - 380 = 0$$

$$n = 19$$

1

Views on the habit of saving

1

QUESTION PAPER CODE 30/2/2
EXPECTED ANSWER/VALUE POINTS

SECTION A

1.

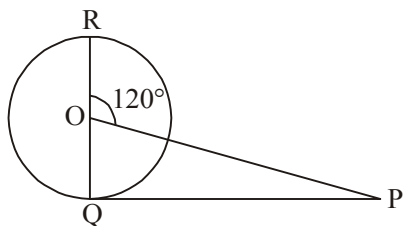

$$\angle POR = \angle OQP + \angle OPQ$$

$$\angle OPQ = 120^\circ - 90^\circ$$

$$= 30^\circ$$

$\frac{1}{2}$
 $\frac{1}{2}$

2. No. of cubes = $\frac{9 \times 8 \times 2}{2 \times 2 \times 2}$

$$= 18$$

$\frac{1}{2}$
 $\frac{1}{2}$

3. $6x^2 - x - k = 0$

$$6\left(\frac{2}{3}\right)^2 - \left(\frac{2}{3}\right) - k = 0$$

$$k = 2$$

$\frac{1}{2}$
 $\frac{1}{2}$

4.

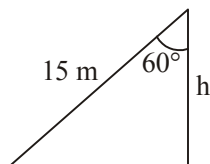

$$\cos 60^\circ = \frac{h}{15}$$

$$h = 7.5 \text{ m}$$

$\frac{1}{2}$
 $\frac{1}{2}$

SECTION B

5. $AB = AC$ (Given)

$$AD = AF \text{ (tangents from external point)}$$

On subtracting,

$$BD = CF$$

$$BD = BE \text{ (tangents from external point)}$$

$$\text{and } CF = EC$$

$$\Rightarrow BE = EC$$

$\frac{1}{2}$

1

6. In leap year = 52 weeks + 2 days

$\frac{1}{2}$

Two days may be, (M, Tu), (Tu, W), (W, Th), (Th, F), (F, Sat)

(Sat, Sun), (Sun, M)

1

Required probability = $\frac{2}{7}$

$\frac{1}{2}$

7.

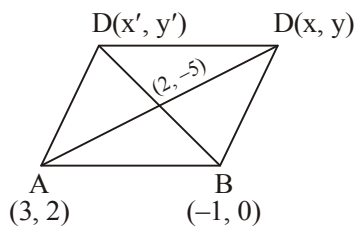

Let other two coordinates are

(x, y) and (x', y')

$$2 = \frac{x+3}{2}$$

$$\Rightarrow x = 1$$

$\frac{1}{2}$

$$\text{and, } -5 = \frac{2+y}{2}$$

$$y = -12$$

$\frac{1}{2}$

$$\text{Again, } \frac{-1+x'}{2} = 2$$

$$x' = 5$$

$\frac{1}{2}$

$$\text{and } \frac{0+y'}{2} = -5$$

$$y' = -10$$

$\frac{1}{2}$

Hence co-ordinates are (1, -12) and (5, -10)

8. $7a_7 = 11a_{11}$

$$7(a + 6d) = 11(a + 10d)$$

$\frac{1}{2}$

$$7a - 11a + 12d - 110d = 0$$

$\frac{1}{2}$

$$-4a - 98d = 0$$

$$a + 17d = 0$$

$\frac{1}{2}$

$$a_{18} = 0$$

$\frac{1}{2}$

(12)

30/2/2

9. Total number of outcomes = 36

$\frac{1}{2}$

$$P(\text{Product appears is less than 18}) = \frac{26}{36} = \frac{13}{18}$$

$1\frac{1}{2}$

10. $\sqrt{3}x^2 + 10x + 7\sqrt{3} = 0$

$$\sqrt{3}x^2 + 7x + 3x + 7\sqrt{3} = 0$$

$\frac{1}{2}$

$$(\sqrt{3}x + 7)(x + \sqrt{3}) = 0$$

1

$$x = \frac{-7}{\sqrt{3}}, -\sqrt{3}$$

$\frac{1}{2}$

SECTION C

11. Co-ordinates of B are (5, 0)

Let co-ordinates of C be (x, y)

$$AC^2 = BC^2$$

1

$$(x - 2)^2 + (y - 0)^2 = (x - 5)^2 + (y - 0)^2$$

$$x^2 + 4 - 4x + y^2 = x^2 + 25 - 10x + y^2$$

$$6x = 21$$

$$x = \frac{7}{2}$$

1

$$(x - 2)^2 + (y - 0)^2 = 9$$

$$\left(\frac{7}{2} - 2\right) + y^2 = 9$$

$$y^2 = 9 - \frac{9}{4}$$

$$y^2 = \frac{27}{4}$$

$$y = \frac{3\sqrt{3}}{2} \text{ (+ve sign to be taken), Co-ordinate of C } \left(\frac{7}{2}, \frac{3\sqrt{3}}{2}\right)$$

1

12. $AB = \sqrt{(-2+0)^2 + (0-2)^2} = 2\sqrt{2}$ units

$BC = \sqrt{(0-2)^2 + (2-2)^2} = 2\sqrt{2}$ units

$CA = \sqrt{(2+2)^2 + (0-0)^2} = 4$ units

$DE = \sqrt{(-4+0)^2 + (0-4)^2} = 4\sqrt{2}$ units

$EF = \sqrt{(0-4)^2 + (4-0)^2} = 4\sqrt{2}$ units

$DF = \sqrt{(-4-4)^2 + (0-2)^2} = 8$ units

$\frac{AB}{DE} = \frac{BC}{EF} = \frac{AC}{DF} = \frac{1}{2}$

$\therefore \Delta ABC \sim \Delta DEF$

1

1

1

13.

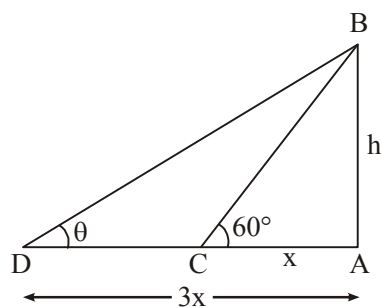

$\tan 60^\circ = \frac{h}{x}$

$h = \sqrt{3}x$

$\tan \theta = \frac{h}{3x}$

$\tan \theta = \frac{\sqrt{3}x}{3x}$

$\tan \theta = \frac{1}{\sqrt{3}}$

$\Rightarrow \theta = 30^\circ$

Correct Figure

$\frac{1}{2}$

1

1

$\frac{1}{2}$

14. 3 marks be given to every attempt

3

15.

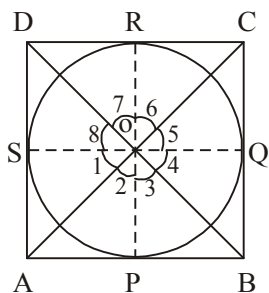

$$\Delta AOS \cong \Delta AOP$$

$$\Rightarrow \angle 1 = \angle 2$$

1

$$\text{Similarly } \angle 4 = \angle 3$$

$$\angle 5 = \angle 6$$

$$\angle 8 = \angle 7$$

$$\Rightarrow (\angle 1 + \angle 8) + (\angle 4 + \angle 5) = (\angle 2 + \angle 3) + (\angle 6 + \angle 7) = 180^\circ$$

1

$$\Rightarrow \angle AOD + \angle BOC = 180^\circ$$

$$\text{and } \angle AOB + \angle COD = 180^\circ$$

1

16.

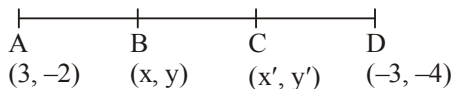

Let the co-ordinates be (x, y) and (x', y')

$$x = \frac{1(-3) + 2(3)}{1+2} = 1$$

$$y = \frac{1(-4) + 2(-2)}{1+2} = \frac{-8}{3}$$

$\frac{1}{2}$

$$x' = \frac{2(-3) + 1(3)}{1+2} = -1$$

$$y' = \frac{2(-4) + 1(-2)}{1+2} = \frac{-10}{3}$$

$\frac{1}{2}$

17. $PA = PB = 4$ cm (tangents from external point)

$\frac{1}{2}$

$$\angle PAB = 180^\circ - 135^\circ$$

$$= 45^\circ$$

$\frac{1}{2}$

$$\angle APB = 180^\circ - 45^\circ - 45^\circ$$

$$= 90^\circ$$

$\frac{1}{2}$

$\Rightarrow \Delta ABP$ is a isosceles right angled triangle

$$\Rightarrow AB^2 = 2AP^2$$

$$= 2(4)^2 = 32$$

1

$$AB = 4\sqrt{2} \text{ cm}$$

$\frac{1}{2}$

18. $(x - a)(x - b) + (x - b)(x - c) + (x - c)(x - a) = 0$
 $\Rightarrow 3x^2 - 2(a + b + c)x + ab + bc + ca = 0$ 1

for equal roots

$$4(a + b + c)^2 - 12(ab + bc + ca) = 0$$
 1

$$2[2a^2 + 2b^2 + 2c^2 - 2ab - 2bc - 2ca] = 0$$

$$\Rightarrow a - b = 0, b - c = 0, c - a = 0$$

$$\Rightarrow a = b, b = c, c = a$$
 1

19. $S_7 = \frac{7}{2}(2a + 6d) = 49 \Rightarrow a + 3d = 7$ 1

$$S_{17} = \frac{17}{2}(2a + 16d) = 289 \Rightarrow a + 8d = 17$$
 $\frac{1}{2}$

On solving,

$$a = 1, d = 2$$
 1

$$S_n = \frac{n}{2}(2(1) + (n - 1)2) = n^2$$
 $\frac{1}{2}$

20. CSA of cylinder = $2\pi(5) \times 12$
 $= 120\pi$ 1

Let length of wire = h cm

$$\text{radius of wire} = \frac{3}{20} \text{ cm}$$
 $\frac{1}{2}$

$$2\pi\left(\frac{3}{20}\right)h = 120\pi$$
 1

$$\Rightarrow h = 400 \text{ cm}$$
 $\frac{1}{2}$

SECTION D

21. Total saving = $190 \times 5 = ₹ 950$ 1

The series $5 + 10 + 20 + \dots$

$$S_n = 950$$

$$\frac{n}{2}(2(5) + (n-1)5) = 950$$
 1

$$n(2 + (n-1)) = 380$$

$$n^2 + n - 380 = 0$$

$$n^2 + 20n - 19n - 380 = 0$$

$$n = 19$$
 1

Views on the habit of saving 1

22.

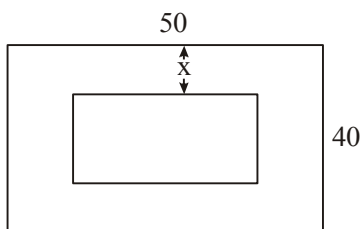

Let width of grass strip = x mts.

area of park – area of pond = 1184

$$(50 \times 40) - (50 - 2x)(40 - 2x) = 1184$$
 1

$$2000 - 2000 + 180x - 4x^2 = 1184$$

$$x^2 - 45x + 296 = 0$$
 1

$$x^2 - 37x - 8x + 296 = 0$$

$$x = 8, 37 \text{ (rejected)}$$
 1

$$\text{Length of pond} = 50 - 16 = 34 \text{ m}$$

$$\text{Breadth of pond} = 40 - 16 = 24 \text{ m}$$
 1

23. For correct given, To prove, construction, figure $4 \times \frac{1}{2} = 2$

for correct proof 2

24.

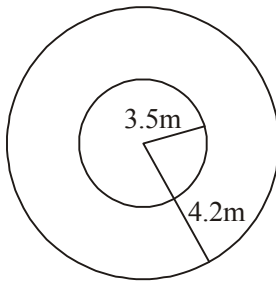

$$r_1 = 3.5\text{m}, r_2 = 4.2\text{m}$$

 $\frac{1}{2}$

$$\text{area of path} = \pi(4.2)^2 - \pi(3.5)^2$$

1

$$= \pi[(7.7) \times 0.7]$$

$$= \frac{22}{7} \times 7.7 \times 0.7$$

$$= 16.94\text{ m}^2$$

 $1\frac{1}{2}$

$$\text{Cost of cementing the path} = 16.94 \times 110$$

$$= ₹ 1863.40$$

1

25.

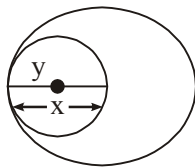
Let radii of circles be x, y ($x > y$)

$$x - y = 6 \quad \dots(1)$$

1

$$\text{and } \pi x^2 + \pi y^2 = 116\pi$$

$$x^2 + y^2 = 116$$

 $\frac{1}{2}$

$$x^2 + (x - 6)^2 = 116$$

$$\Rightarrow x^2 + x^2 + 36 - 12x = 116$$

$$\Rightarrow x^2 - 6x - 40 = 0$$

1

$$(x - 10)(x + 4) = 0$$

1

$$\Rightarrow x = 10\text{ cm (rejecting -ve value)}$$

 $\frac{1}{2}$

$$\text{and } y = 4\text{ cm}$$

26. Let height of embankment be h mts

$$17(1.5)2 \times 14 = \pi[(6.5)^2 - (1.5)^2] \times 2$$

2

$$2.25 \times 14 = 5 \times 8 \times h$$

1

$$\Rightarrow h = 0.7875\text{ m}$$

1

27. (i) $P(\text{bears two digit number}) = \frac{81}{90}$ or $\frac{9}{10}$

2

(ii) $P(\text{a number divisible by } 5) = \frac{18}{90}$ or $\frac{1}{5}$

2

28. $\frac{1}{a+b+x} - \frac{1}{x} = \frac{1}{a} + \frac{1}{b}$ 1

$$\frac{-(a+b)}{x^2 + (a+b)x} = \frac{b+a}{ab}$$
 1

$$\Rightarrow x^2 + (a+b)x + ab = 0$$

$$(x+a)(x+b) = 0$$
 1

$$x = -a, -b$$
 1

29. Constructing correct circles 1

Constructing correct tangents to each circle 3

30. 1

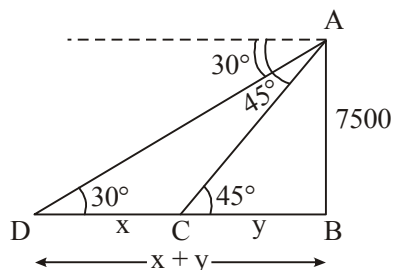

For correct figure 1

$$\tan 45^\circ = \frac{7500}{y}$$

$$y = 7500$$
 1

$$\tan 30^\circ = \frac{7500}{x+y}$$

$$x + 7500 = 7500\sqrt{3}$$
 1

$$x = 7500(\sqrt{3} - 1) \text{ m}$$

$$= 7500 \times 0.73 = 5475 \text{ m}$$
 1

31.

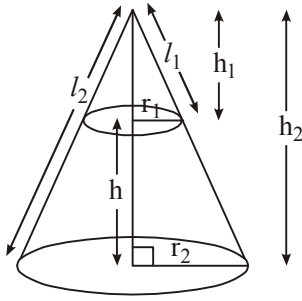

$$\frac{r_1}{r_2} = \frac{h_1}{h_2} = \frac{l_1}{l_2} \quad 1$$

$$\pi r_2 l_2 - \pi r_1 l_1 = \frac{8}{9} \pi r_2 l_2 \quad 1$$

$$\frac{1}{9} r_2 l_2 = r_1 l_1$$

$$\frac{1}{9} = \frac{r_1}{r_2} \times \frac{l_1}{l_2}$$

$$\Rightarrow \left(\frac{h_1}{h_2} \right)^2 = \frac{1}{9}$$

$$\frac{h_1}{h_2} = \frac{1}{3} \quad 1$$

$$\text{height of small cone} = \frac{1}{3} h_2$$

$$\text{height of frustum} = \frac{2}{3} h_2 \quad \frac{1}{2}$$

$$\text{Required Ratio} = \frac{1/3}{2/3} = \frac{1}{2} \quad \frac{1}{2}$$

QUESTION PAPER CODE 30/2/3
EXPECTED ANSWER/VALUE POINTS

SECTION A

1. No. of cubes = $\frac{9 \times 8 \times 2}{2 \times 2 \times 2}$ $\frac{1}{2}$

= 18 $\frac{1}{2}$

2.  $\angle POR = \angle OQP + \angle OPQ$

$\angle OPQ = 120^\circ - 90^\circ$ $\frac{1}{2}$

= 30° $\frac{1}{2}$

3.  $\cos 60^\circ = \frac{h}{15}$ $\frac{1}{2}$

$h = 7.5 \text{ m}$ $\frac{1}{2}$

4. $6x^2 - x - k = 0$

$6\left(\frac{2}{3}\right)^2 - \left(\frac{2}{3}\right) - k = 0$ $\frac{1}{2}$

$k = 2$ $\frac{1}{2}$

SECTION B

5. Let other two coordinates are

(x, y) and (x', y')

$2 = \frac{x+3}{2}$

$\Rightarrow x = 1$ $\frac{1}{2}$

and, $-5 = \frac{2+y}{2}$

$y = -12$ $\frac{1}{2}$

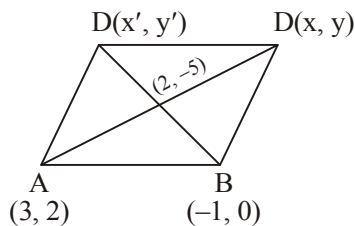

$$\text{Again, } \frac{-1 + x'}{2} = 2$$

$$x' = 5$$

$$\text{and } \frac{0 + y'}{2} = -5$$

$$y' = -10$$

Hence co-ordinates are (1, -12) and (5, -10)

6. AB = AC (Given)

AD = AF (tangents from external point)

On subtracting,

$$BD = CF$$

BD = BE (tangents from external point)

and CF = EC

$$\Rightarrow BE = EC$$

7. In leap year = 52 weeks + 2 days

Two days may be, (M, Tu), (Tu, W), (W, Th), (Th, F), (F, Sat)

(Sat, Sun), (Sun, M)

$$\text{Required probability} = \frac{2}{7}$$

8. $7a_7 = 11a_{11}$

$$7(a + 6d) = 11(a + 10d)$$

$$7a - 11a + 12d - 110d = 0$$

$$-4a - 68d = 0$$

$$a + 17d = 0$$

$$a_{18} = 0$$

$\frac{1}{2}$

$\frac{1}{2}$

$\frac{1}{2}$

1

$\frac{1}{2}$

1

$\frac{1}{2}$

$\frac{1}{2}$

$\frac{1}{2}$

$\frac{1}{2}$

$\frac{1}{2}$

9. Total number of outcomes = 36

$\frac{1}{2}$

$$P(\text{Product appears is less than 18}) = \frac{26}{36} = \frac{13}{18}$$

$1\frac{1}{2}$

10. $\sqrt{3}x^2 - 2x - 8\sqrt{3} = 0$

$$\sqrt{3}x^2 - 6x + 4x - 8\sqrt{3} = 0$$

$\frac{1}{2}$

$$\sqrt{3}x(x - 2\sqrt{3}) + 4(x - 2\sqrt{3}) = 0$$

1

$$x = \frac{-4}{\sqrt{3}}, 2\sqrt{3}$$

$\frac{1}{2}$

SECTION C

11. $AB = \sqrt{(-2+0)^2 + (0-2)^2} = 2\sqrt{2}$ units

$$BC = \sqrt{(0-2)^2 + (2-2)^2} = 2\sqrt{2}$$
 units

$$CA = \sqrt{(2+2)^2 + (0-0)^2} = 4$$
 units

1

$$DE = \sqrt{(-4+0)^2 + (0-4)^2} = 4\sqrt{2}$$
 units

$$EF = \sqrt{(0-4)^2 + (4-0)^2} = 4\sqrt{2}$$
 units

$$DF = \sqrt{(-4-4)^2 + (0-2)^2} = 8$$
 units

1

$$\frac{AB}{DE} = \frac{BC}{EF} = \frac{AC}{DF} = \frac{1}{2}$$

$$\therefore \Delta ABC \sim \Delta DEF$$

1

12. Co-ordinates of B are (5, 0)

Let co-ordinates of C be (x, y)

$$AC^2 = BC^2$$

1

$$(x-2)^2 + (y-0)^2 = (x-5)^2 + (y-0)^2$$

$$x^2 + 4 - 4x + y^2 = x^2 + 25 - 10x + y^2$$

$$6x = 21$$

$$x = \frac{7}{2}$$

$$(x - 2)^2 + (y - 0)^2 = 9$$

$$\left(\frac{7}{2} - 2\right) + y^2 = 9$$

$$y^2 = 9 - \frac{9}{4}$$

$$y^2 = \frac{27}{4}$$

$$y = \frac{3\sqrt{3}}{2} \text{ (+ve sign to be taken), Co-ordinate of C } \left(\frac{7}{2}, \frac{3\sqrt{3}}{2}\right)$$

1

1

13. 3 marks be given to every attempt

3

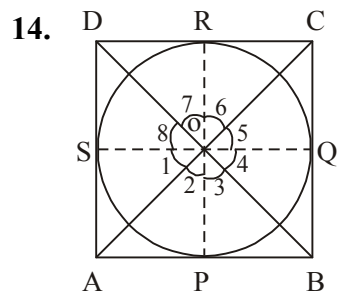

$$\Delta AOS \cong \Delta AOP$$

$$\Rightarrow \angle 1 = \angle 2$$

$$\text{Similarly } \angle 4 = \angle 3$$

$$\angle 5 = \angle 6$$

$$\angle 8 = \angle 7$$

$$\Rightarrow (\angle 1 + \angle 8) + (\angle 4 + \angle 5) = (\angle 2 + \angle 3) + (\angle 6 + \angle 7) = 180^\circ \quad 1$$

$$\Rightarrow \angle AOD + \angle BOC = 180^\circ$$

$$\text{and } \angle AOB + \angle COD = 180^\circ$$

1

1

15.

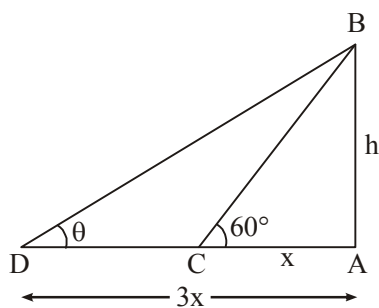

$$\tan 60^\circ = \frac{h}{x}$$

$$h = \sqrt{3}x$$

$$\tan \theta = \frac{h}{3x}$$

$$\tan \theta = \frac{\sqrt{3}x}{3x}$$

$$\tan \theta = \frac{1}{\sqrt{3}}$$

$$\Rightarrow \theta = 30^\circ$$

Correct Figure $\frac{1}{2}$

1

1

$\frac{1}{2}$

$\frac{1}{2}$

$\frac{1}{2}$

$\frac{1}{2}$

1

$\frac{1}{2}$

16. PA = PB = 4 cm (tangents from external point)

$$\angle PAB = 180^\circ - 135^\circ$$

$$= 45^\circ$$

$$\angle APB = 180^\circ - 45^\circ - 45^\circ$$

$$= 90^\circ$$

$\Rightarrow \triangle ABP$ is a isosceles right angled triangle

$$\Rightarrow AB^2 = 2AP^2$$

$$= 2(4)^2 = 32$$

$$AB = 4\sqrt{2} \text{ cm}$$

$\frac{1}{2}$

$\frac{1}{2}$

17.

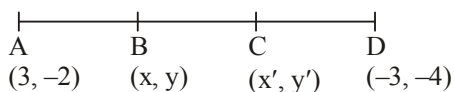

Let the co-ordinates be (x, y) and (x', y')

$$x = \frac{1(-3) + 2(3)}{1 + 2} = 1$$

$$y = \frac{1(-4) + 2(-2)}{1 + 2} = \frac{-8}{3}$$

$$x' = \frac{2(-3) + 1(3)}{1 + 2} = -1$$

$$y' = \frac{2(-4) + 1(-2)}{1 + 2} = \frac{-10}{3}$$

$1 \frac{1}{2}$

$1 \frac{1}{2}$

18. $(c^2 - ab)x^2 - 2(a^2 - bc)x + b^2 - ac = 0$

For equal roots

$$4(a^2 - bc)^2 - 4(c^2 - ab)(b^2 - ac) = 0 \quad 1$$

$$a^4 + b^2c^2 - 2a^2bc - c^2b^2 + c^2a + ab^3 - a^2bc = 0 \quad 1$$

$$a(a^3 + b^3 + c^3 - 3abc) = 0 \quad \frac{1}{2}$$

either $a = 0$ or $a^3 + b^3 + c^3 = 3abc$ 1/2

19. $S_{10} = 210$

$$\frac{10}{2}(2a + 9d) = 210$$

$$2a + 9d = 42 \quad \dots(1) \quad 1$$

$$a_{36} = a + 35d$$

$$a_{50} = a + 49d$$

$$\text{Sum of last 15 terms} = \frac{15}{2}(a + 35d + a + 49d)$$

$$2565 = \frac{15}{2}(2a + 84d)$$

$$\Rightarrow a + 42d = 171 \quad \dots(2) \quad 1$$

Solving (1) and (2)

$$a = 3, b = 4 \quad 1$$

\therefore AP is 3, 7, 11...

20. Let the rise in level of water be h cm

$$\frac{4}{3}\pi(3)^3 = \pi(6)^2h \quad 2$$

Solving $h = 1$ 1

SECTION D

21. For correct given, To prove, construction, figure $4 \times \frac{1}{2} = 2$
for correct proof 2

22. Total saving = $190 \times 5 = ₹ 950$ 1

The series $5 + 10 + 20 + \dots$

$$S_n = 950$$

$$\frac{n}{2}(2(5) + (n - 1)5) = 950 \quad 1$$

$$n(2 + (n - 1)) = 380$$

$$n^2 + n - 380 = 0$$

$$n^2 + 20n - 19n - 380 = 0$$

$$n = 19 \quad 1$$

Views on the habit of saving 1

23.

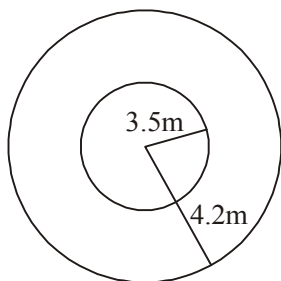

$$r_1 = 3.5\text{m}, r_2 = 4.2\text{ m} \quad \frac{1}{2}$$

$$\text{area of path} = \pi(4.2)^2 - \pi(3.5)^2 \quad 1$$

$$= \pi[(7.7) \times 0.7]$$

$$= \frac{22}{7} \times 7.7 \times 0.7$$

$$= 16.94 \text{ m}^2 \quad 1 \frac{1}{2}$$

$$\text{Cost of cementing the path} = 16.94 \times 110$$

$$= ₹ 1863.40 \quad 1$$

24.

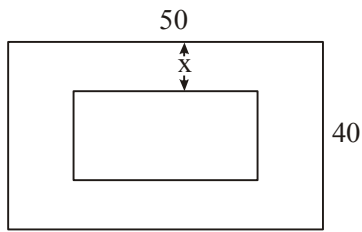
Let width of grass strip be x mts.

area of park – area of pond = 1184

$$(50 \times 40) - (50 - 2x)(40 - 2x) = 1184 \quad 1$$

$$2000 - 2000 + 180x - 4x^2 = 1184$$

$$x^2 - 45x + 296 = 0 \quad 1$$

$$x^2 - 37x - 8x + 296 = 0$$

$$x = 8, 37 \text{ (rejected)} \quad 1$$

$$\text{Length of pond} = 50 - 16 = 34 \text{ m} \quad]$$

$$\text{Breadth of pond} = 40 - 16 = 24 \text{ m} \quad] \quad 1$$

25.

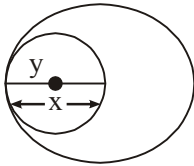
Let radii of circles be x, y ($x > y$)

$$x - y = 6 \quad \dots(1) \quad 1$$

$$\text{and } \pi x^2 + \pi y^2 = 116\pi$$

$$x^2 + y^2 = 116 \quad \frac{1}{2}$$

$$x^2 + (x - 6)^2 = 116$$

$$\Rightarrow x^2 + x^2 + 36 - 12x = 116$$

$$\Rightarrow x^2 - 6x - 40 = 0 \quad 1$$

$$(x - 10)(x + 4) = 0 \quad 1$$

$$\Rightarrow x = 10 \text{ cm (rejecting -ve value)} \quad \frac{1}{2}$$

$$\text{and } y = 4 \text{ cm}$$

$$26. \quad (i) P(\text{bears two digit number}) = \frac{81}{90} \text{ or } \frac{9}{10} \quad 2$$

$$(ii) P(\text{a number divisible by 5}) = \frac{18}{90} \text{ or } \frac{1}{5} \quad 2$$

27. Let height of embankment be h mts

$$17(1.5)2 \times 14 = \pi[(6.5)^2 - (1.5)^2] \times 2 \quad 2$$

$$2.25 \times 14 = 5 \times 8 \times h \quad 1$$

$$\Rightarrow h = 0.7875 \text{ m} \quad 1$$

28. $4x^2 + 4bx - (a^2 - b^2) = 0$

$D = 16b^2 + 16(a^2 - b^2)$

$= 16a^2$

$x = \frac{-4b \pm 4a}{2 \times 4}$

$x = \frac{-b - a}{2}, x = \frac{-b + a}{2}$

1

2

1

29. For constructing correct circle

1

For constructing correct pair of tangents

3

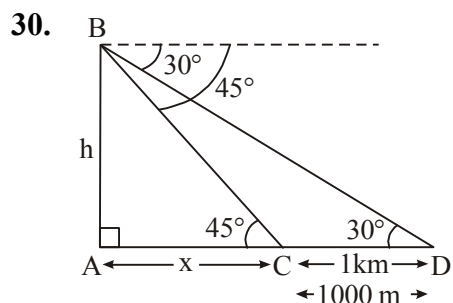

For correct figure

1

$\tan 45^\circ = \frac{h}{x}$

$x = h$

1

$\tan 30^\circ = \frac{h}{x + 1000}$

$h + 1000 = \sqrt{3}h$

1

$h(\sqrt{3} - 1) = 1000$

$h = \frac{1000}{\sqrt{3} - 1}$ or $500(\sqrt{3} + 1)m$

1

31.

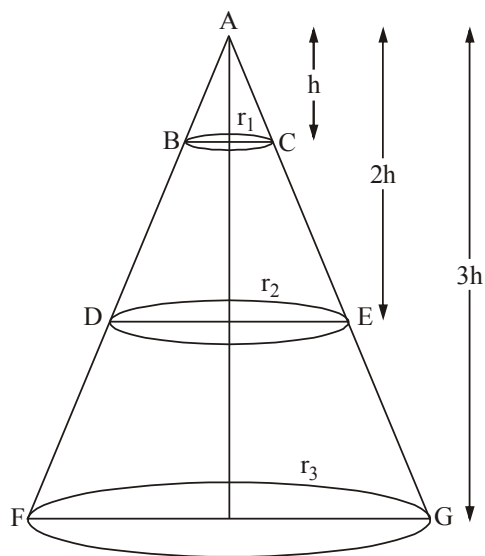

$$\frac{r_1}{r_2} = \frac{h}{2h}$$

$$2r_1 = r_2$$

$$\frac{r_1}{r_3} = \frac{h}{3h}$$

$$3r_1 = r_3$$

$$\text{Volume of cone ABC} = \frac{1}{3} \pi r_1^2 h$$

$$\text{Volume of frustum BCED} = \frac{1}{3} \pi r_2^2 (2h) - \frac{1}{3} \pi r_1^2 h$$

$$= \frac{1}{3} \pi (2r_1)^2 \times (2h) - \frac{1}{3} \pi r_1^2 h$$

$$= \frac{7}{3} \pi r_1^2 h$$

$$\text{Volume of frustum DEGF} = \frac{1}{3} \pi r_3^2 (3h) - \frac{1}{3} \pi (2r_2)^2 \times 2h$$

$$= \frac{1}{3} \pi r_1^2 h (27 - 8)$$

$$= \frac{19}{3} \pi r_1^2 h$$

$$\text{Required Ratio} = \frac{1}{3} \pi r_1^2 h : \frac{7}{3} \pi r_1^2 h : \frac{19}{3} \pi r_1^2 h$$

$$= 1 : 7 : 19$$

 $\frac{1}{2}$ $\frac{1}{2}$ $\frac{1}{2}$

1

1

 $\frac{1}{2}$