

UNIT 9

PERIMETER AND AREA

(A) Main Concepts and Results

- Perimeter of a closed figure is the distance around it while area is the measure of the part of plane or region enclosed by it.
- Perimeter of a regular polygon = Number of sides \times Length of one side.
- Perimeter of a square = $4 \times$ side



Fig. 9.1

- Perimeter of a rectangle = $2(l + b)$



Fig. 9.2

- Area of square = side \times side
- Area of rectangle = $l \times b$
- Area of parallelogram = $b \times h$
- Area of triangle = $\frac{1}{2} \times b \times h$

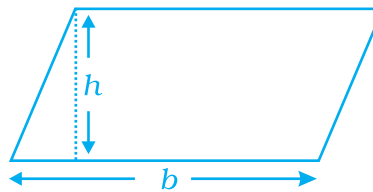

Fig. 9.3

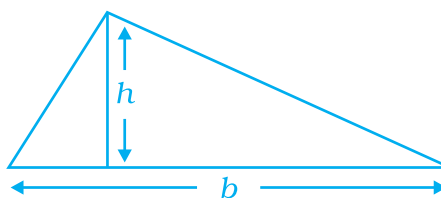

Fig. 9.4

- The distance around a circle is known as its circumference.
- The ratio of circumference and diameter of a circle is a constant and is denoted by π (pi).
- Approximate value of π is taken as $\frac{22}{7}$ or 3.14
- Circumference of a circle of radius r is $2\pi r$,
- Area of a circle of radius r is πr^2 .

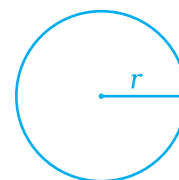
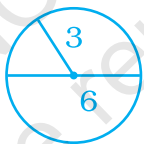

Fig. 9.5

CIRCUMFERENCE OF A CIRCLE		
Words	Numbers	Formula
The circumference C of a circle is π times the diameter d , or 2π times the radius r .	 $C = \pi \times 6$ $= 2\pi \times 3$ $= 18.8 \text{ units}$	$C = \pi d$ or $C = 2\pi r$

(B) Solved Examples

In Examples 1 and 2, there are four options, out of which one is correct. Choose the correct one.

Example 1: Following rectangle is composed of 8 congruent parts.

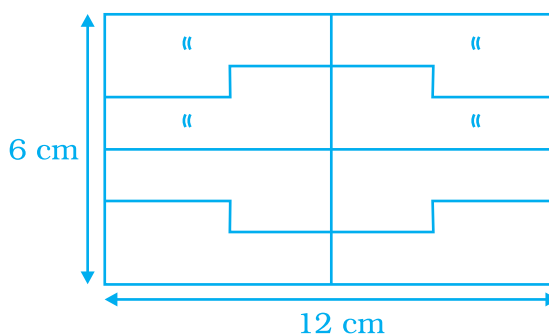

Fig. 9.6

Area of each part is

- (a) 72 cm^2 (b) 36 cm^2 (c) 18 cm^2 (d) 9 cm^2

Solution: Correct answer is (d).

Example 2: Area of a right triangle is 54 cm^2 . If one of its legs is 12 cm long, its perimeter is

- (a) 18 cm (b) 27 cm (c) 36 cm (d) 54 cm

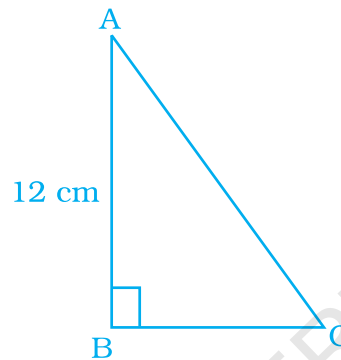



Fig. 9.7

Solution: Correct answer is (c).

AREA OF A CIRCLE		
Words	Numbers	Formula
The area A of a circle is π times the square of the radius r .	 $A = \pi \times 3^2$ $= 9\pi$ $= 28.3 \text{ units}$	$A = \pi r^2$

In Examples 3 to 6, fill in the blanks to make it a statement true.

Example 3: Area of parallelogram QPON is _____ cm^2 .

Solution: 48 cm^2

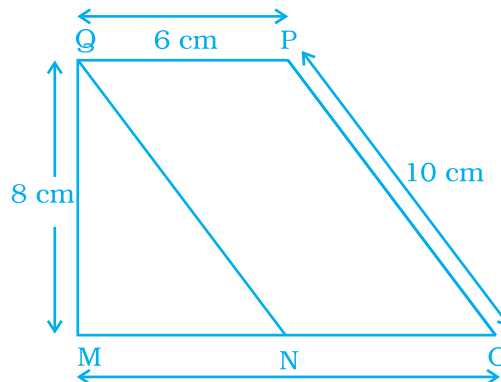

Fig. 9.8

Example 4: 1 hectare = _____ cm^2

Solution: 10,00,00,000

Example 5: _____ squares of each side 1 m makes a square of side 5 km.

Solution: 2,50,00,000

Example 6: All the congruent triangles have _____ area.

Solution: equal

In Examples 7 to 10, state whether the statements are True or False.

Example 7: All the triangles equal in area are congruent.

Solution: False

Example 8: The area of any parallelogram ABCD, is $AB \times BC$.

Solution: False.

Example 9: Ratio of the circumference and the diameter of a circle is more than 3.

Solution: True

Example 10: A nursery school play ground is 160 m long and 80 m wide. In it $80 \text{ m} \times 80 \text{ m}$ is kept for swings and in the remaining portion, there is 1.5 m wide path parallel to its width and parallel to its remaining length as shown in Fig. 9.9. The remaining area is covered by grass. Find the area covered by grass.

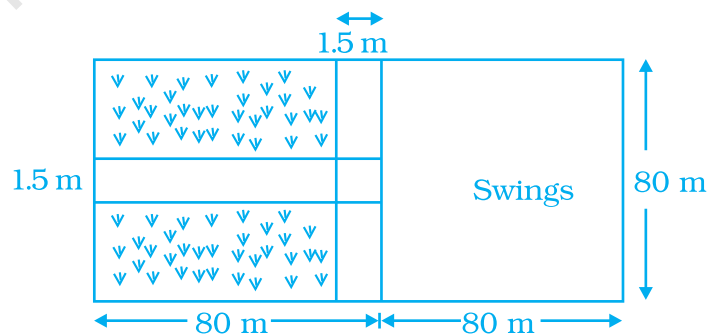

Fig. 9.9

Solution : Area of school playground is $160 \text{ m} \times 80 \text{ m} = 12800 \text{ m}^2$

Area kept for swings = $80 \text{ m} \times 80 \text{ m} = 6400 \text{ m}^2$

Area of path parallel to the width of playground
 = $80 \text{ m} \times 1.5 \text{ m} = 120 \text{ m}^2$

Area of path parallel to the remaining length of
 playground

= $80 \text{ m} \times 1.5 \text{ m} = 120 \text{ m}^2$.

Area common to both paths = $1.5 \text{ m} \times 1.5 \text{ m} = 2.25 \text{ m}^2$.

[since it is taken twice for measurement it is to be
 subtracted from the area of paths]

Total area covered by both the paths

= $(120 + 120 - 2.25) \text{ m}^2$

= 237.75 m^2 .

Area covered by grass = Area of school playground - (Area
 kept for swings + Area covered by paths)

= $12800 \text{ m}^2 - [6400 + 237.75] \text{ m}^2$

= $(12800 - 6637.75) \text{ m}^2$

= 6162.25 m^2 .

Any side of a triangle can be the **base**. The diagrams below show the length of the **base** (b) and the **height** (h) of several triangles.

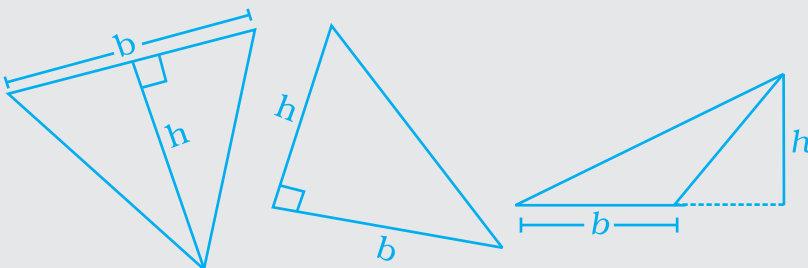

h represents the height.

b represents the length of the base.

Example 11: In Fig. 9.10, ABCD is a parallelogram, in which $AB = 8$ cm, $AD = 6$ cm and altitude $AE = 4$ cm. Find the altitude corresponding to side AD.

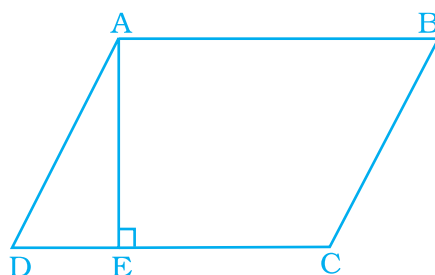

Fig. 9.10

Solution: Area of parallelogram ABCD = $AB \times AE = 8 \times 4 \text{ cm}^2 = 32 \text{ cm}^2$

Let altitude corresponding to AD be h . Then,

$$h \times AD = 32$$

or $h \times 6 = 32$

or $h = \frac{32}{6} = \frac{16}{3}$

Thus, altitude corresponding to AD is $\frac{16}{3}$ cm.

Example 12: A rectangular shaped swimming pool with dimensions $30 \text{ m} \times 20 \text{ m}$ has 5 m wide cemented path along its length and 8 m wide path along its width (as shown in Fig. 9.11). Find the cost of cementing the path at the rate of Rs 200 per m^2 .

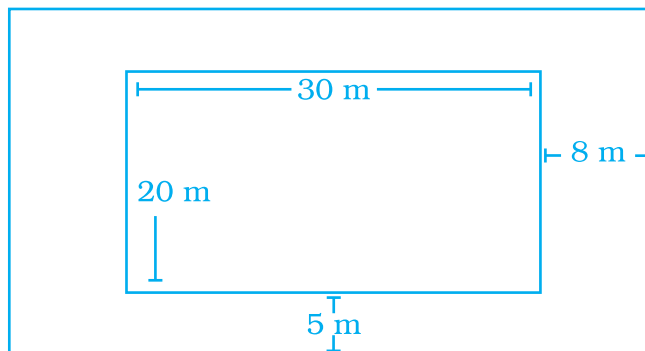

Fig. 9.11

Solution: Area covered by swimming pool = $30 \text{ m} \times 20 \text{ m} = 600 \text{ m}^2$.
 Length of outer rectangle = $(30 + 8 + 8) \text{ m} = 46 \text{ m}$
 and its breadth = $(20 + 5 + 5) \text{ m} = 30 \text{ m}$
 So, the area of outer rectangle

$$= 46 \text{ m} \times 30 \text{ m} = 1380 \text{ m}^2.$$
 Area of cemented path =
 Area of outer rectangle – Area of swimming pool

$$= (1380 - 600) \text{ m}^2 = 780 \text{ m}^2.$$
 Cost of cementing 1 m^2 path = ₹ 200
 So, total cost of cementing the path

$$= ₹ 780 \times 200$$

$$= ₹ 156000$$

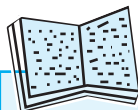

Vocabulary

To become familiar with some of the vocabulary terms consider the following.

1. The word **circumference** contains the prefix circum-, which means “around”. What do you think about the circumference of a circle?
2. The Greek prefix peri- means “around,” and the root meter means “means of measuring.” “What do you suppose **perimeter** means?”
3. The Greek prefix dia- means “across.” What do you think about the **diameter** of a circle?

Example 13: Circumference of a circle is 33 cm. Find its area.

Solution: Let the radius of the circle be r .

Then, $2\pi r = 33$

i.e.,
$$r = \frac{33}{2\pi} = \frac{33}{2} \times \frac{7}{22} = \frac{21}{4}$$

Thus, radius is $\frac{21}{4}$ cm

So, area of the circle = $\pi r^2 = \frac{22}{7} \cdot \frac{21}{4} \cdot \frac{21}{4} = \frac{693}{8}$

Thus, area of the circle is $\frac{693}{8}$ cm².

Example 14: Rectangle ABCD is formed in a circle as shown in Fig. 9.12. If AE = 8 cm and AD = 5 cm, find the perimeter of the rectangle.

Solution:

DE = EA + AD = (8 + 5)cm = 13 cm

DE is the radius of the circle.

Also, DB is the radius of the circle.

Next, AC = DB [Since diagonals of a rectangle are equal in length]

Therefore, AC = 13 cm.

From $\triangle ADC$, $DC^2 = AC^2 - AD^2 = 13^2 - 5^2 = 169 - 25 = 144 = 12^2$

So, DC = 12

Thus, length of DC is 12 cm.

Hence, perimeter of the rectangle ABCD = $2(12 + 5)\text{cm} = 34$ cm.

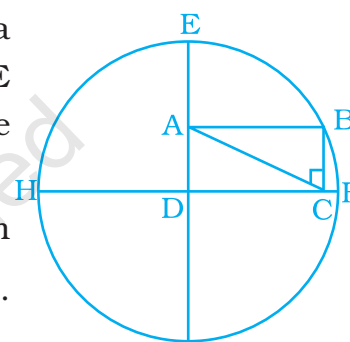
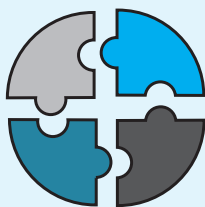

Fig. 9.12

Application on Problem Solving Strategy



Example 15

Find the area of a parallelogram shaped shaded region of Fig. 9.13. Also, find the area of each triangle. What is the ratio of area of shaded portion to the remaining area of rectangle?

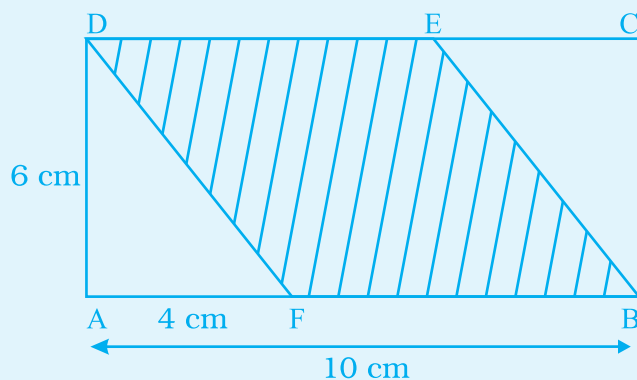

Fig. 9.13

Solution:**Understand and Explore the Problem**

- What information is given in the question?
 - (i) It is given that ABCD is a rectangle whose $l = 10$ cm and $b = 6$ cm.
 - (ii) In the figure $AF = 4$ cm
 - (iii) To find the area of shaded region.

Plan a Strategy

- First recall the areas of a triangle and a rectangle
 Area of a rectangle = length \times breadth
 Area of a triangle = $\frac{1}{2} \times$ base \times altitude
- In the Fig. 9.13, DAF is a right triangle in which $\angle A = 90^\circ$.
 ABCD is a rectangle and DEBF is a parallelogram,
 Since $\triangle DAF \cong \triangle BCE$, therefore their areas will be equal.

Solve

- Area of $\triangle DAF = \frac{1}{2} \times 4 \times 6 \text{ cm}^2$

- Area of rectangle = $l \times b$
 $= 10 \text{ cm} \times 6 \text{ cm} = 60 \text{ cm}^2$
- Area of shaded region = Area of rectangle – Area of $\triangle DAF$
 – Area of $\triangle BCE = (60 - 12 - 12) \text{ cm}^2$
 $= (60 - 24) \text{ cm}^2 = 36 \text{ cm}^2$
- Area of remaining part = Area of Rectangle – Area of shaded portion
 $= (60 - 36) \text{ cm}^2 = 24 \text{ cm}^2$

Ratio = Area of shaded portion : Area of remaining rectangle
 $= 36 : 24 = 3 : 2$



Revise

- Area of shaded portion + Area of remaining portion = Area of rectangle
 That is, $(36 + 24) \text{ cm}^2 = 60 \text{ cm}^2$

Think and Discuss

1. We can also calculate area of shaded portion by using area of parallelogram. Think what would be its base and altitude.
2. Can you frame, questions in which areas of all the plane figures rectangle, square, triangle and a parallelogram are to be calculated?

(C) Exercise

In the Questions 1 to 37, there are four options, out of which one is correct. Choose the correct one.

1. Observe the shapes 1, 2, 3 and 4 in the figures. Which of the following statements is not correct?

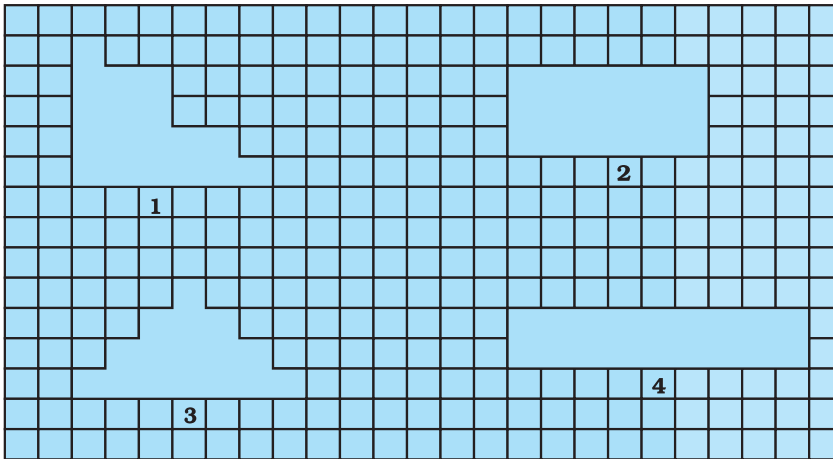

- (a) Shapes 1, 3 and 4 have different areas and different perimeters.
- (b) Shapes 1 and 4 have the same area as well as the same perimeter.
- (c) Shapes 1, 2 and 4 have the same area.
- (d) Shapes 1, 3 and 4 have the same perimeter.

Think and Discuss

1. **Compare** the area of a rectangle with base b and height h with the area of a rectangle with base $2b$ and height $2h$.
2. **Express** the formulas for the area and perimeter of a square using s for the length of a side.

2. A rectangular piece of dimensions $3\text{ cm} \times 2\text{ cm}$ was cut from a rectangular sheet of paper of dimensions $6\text{ cm} \times 5\text{ cm}$ (Fig. 9.14).

Area of remaining sheet of paper is

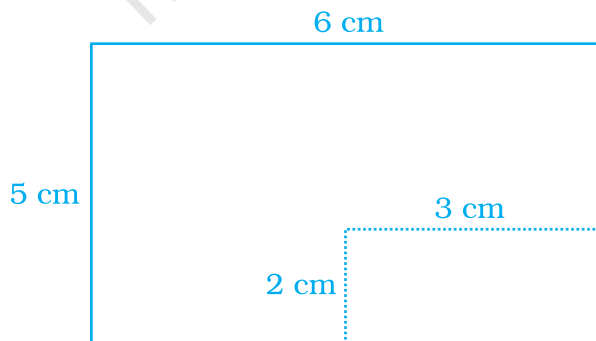

Fig. 9.14

- (a) 30 cm^2 (b) 36 cm^2 (c) 24 cm^2 (d) 22 cm^2

3. 36 unit squares are joined to form a rectangle with the least perimeter. Perimeter of the rectangle is
 (a) 12 units (b) 26 units
 (c) 24 units (d) 36 units
4. A wire is bent to form a square of side 22 cm. If the wire is rebent to form a circle, its radius is
 (a) 22 cm (b) 14 cm (c) 11 cm (d) 7 cm

Think and Discuss

1. Give the formula for the area of a circle in terms of the diameter d .

5. Area of the circle obtained in Question 4 is
 (a) 196 cm^2 (b) 212 cm^2 (c) 616 cm^2 (d) 644 cm^2
6. Area of a rectangle and the area of a circle are equal. If the dimensions of the rectangle are $14 \text{ cm} \times 11 \text{ cm}$, then radius of the circle is
 (a) 21 cm (b) 10.5 cm (c) 14 cm (d) 7 cm.
7. Area of shaded portion in Fig. 9.15 is
 (a) 25 cm^2 (b) 15 cm^2 (c) 14 cm^2 (d) 10 cm^2

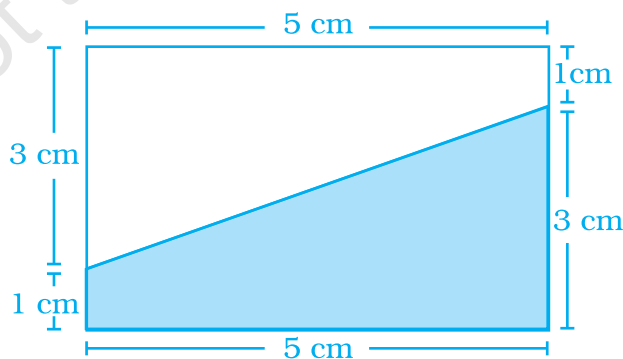

Fig. 9.15

8. Area of parallelogram ABCD (Fig. 9.16) is not equal to
 (a) $DE \times DC$ (b) $BE \times AD$ (c) $BF \times DC$ (d) $BE \times BC$

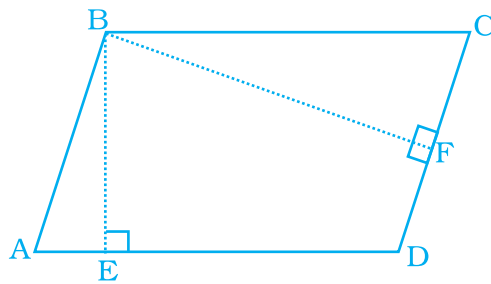

Fig. 9.16

Think and Discuss

1. **Describe** what happens to the area of a triangle when the base is doubled and the height remains the same.
2. **Describe** what happens to the area of a parallelogram when the length of its base is doubled but the height remains the same.

9. Area of triangle MNO of Fig. 9.17 is

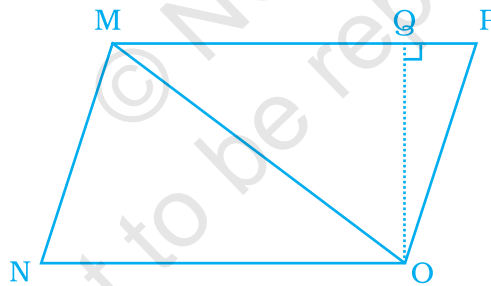

Fig. 9.17

- (a) $\frac{1}{2} MN \times NO$ (b) $\frac{1}{2} NO \times MO$ (c) $\frac{1}{2} MN \times OQ$ (d) $\frac{1}{2} NO \times OQ$
10. Ratio of area of $\triangle MNO$ to the area of parallelogram MNOP in the same figure 9.17 is
- (a) 2 : 3 (b) 1 : 1 (c) 1 : 2
 (d) 2 : 1
11. Ratio of areas of $\triangle MNO$, $\triangle MOP$ and $\triangle MPQ$ in Fig. 9.18 is
- (a) 2 : 1 : 3 (b) 1 : 3 : 2 (c) 2 : 3 : 1 (d) 1 : 2 : 3

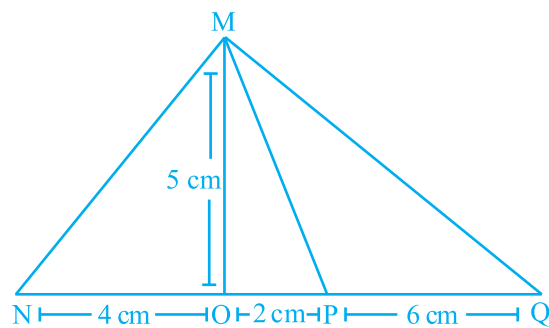

Fig. 9.18

12. In Fig. 9.19, EFGH is a parallelogram, altitudes FK and FI are 8 cm and 4 cm respectively. If EF = 10 cm, then area of EFGH is

- (a) 20 cm^2 (b) 32 cm^2
 (c) 40 cm^2 (d) 80 cm^2

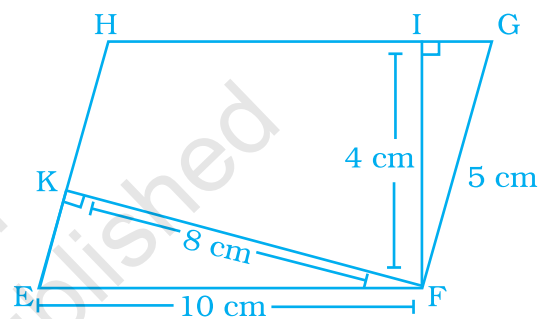

Fig. 9.19

The Taj Mahal, a world famous structure, is the most visited attraction in India. It was created in the 17th century by Emperor Shah Jahan to honour the memory of his beloved wife Mumtaz Mahal. The design of the Taj Mahal is based on the number four and its multiples.



Think about it

1. The garden at the Taj Mahal was laid out in four squares of the same size. Each square was divided into four flower beds, with 400 flowers in each bed. How many flowers were in the garden?
2. The central chamber of the Taj Mahal was built in the shape of an octagon. How is an octagon related to the number 4?

13. In reference to a circle the value of π is equal to

- (a) $\frac{\text{area}}{\text{circumference}}$ (b) $\frac{\text{area}}{\text{diameter}}$
 (c) $\frac{\text{circumference}}{\text{diameter}}$ (d) $\frac{\text{circumference}}{\text{radius}}$

14. Circumference of a circle is always

- (a) more than three times of its diameter
 (b) three times of its diameter
 (c) less than three times of its diameter
 (d) three times of its radius

15. Area of triangle PQR is 100 cm^2 (Fig. 9.20). If altitude QT is 10 cm, then its base PR is

- (a) 20 cm (b) 15 cm (c) 10 cm (d) 5 cm

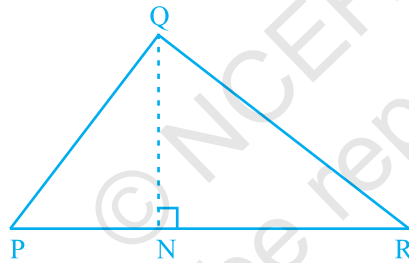

Fig. 9.20

16. In Fig. 9.21, if $PR = 12 \text{ cm}$, $QR = 6 \text{ cm}$ and $PL = 8 \text{ cm}$, then QM is

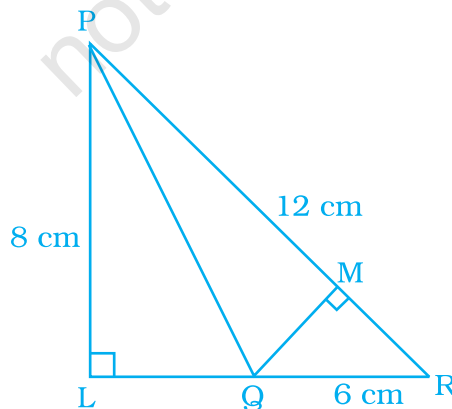

Fig. 9.21

- (a) 6 cm (b) 9 cm (c) 4 cm (d) 2 cm

17. In Fig. 9.22 $\triangle MNO$ is a right-angled triangle. Its legs are 6 cm and 8 cm long. Length of perpendicular NP on the side MO is

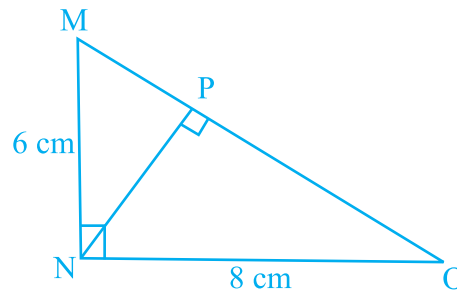
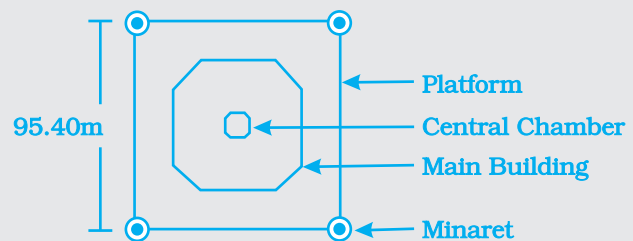

Fig. 9.22

- (a) 4.8 cm (b) 3.6 cm (c) 2.4 cm (d) 1.2 cm
18. Area of a right-angled triangle is 30 cm^2 . If its smallest side is 5 cm, then its hypotenuse is
 (a) 14 cm (b) 13 cm (c) 12 cm (d) 11 cm
19. Circumference of a circle of diameter 5 cm is
 (a) 3.14 cm (b) 31.4 cm (c) 15.7 cm (d) 1.57 cm
20. Circumference of a circle disc is 88 cm. Its radius is
 (a) 8 cm (b) 11 cm (c) 14 cm (d) 44 cm



- a. The Taj Mahal stands on a square platform that is 95.40 m on each side. What is the area of this square in square metres?
- b. The floor area of the main building is 3214 m^2 . What is the area of the part of the platform that is not covered by the main building?

- 21.** Length of tape required to cover the edges of a semicircular disc of radius 10 cm is
(a) 62.8 cm (b) 51.4 cm (c) 31.4 cm (d) 15.7 cm
- 22.** Area of circular garden with diameter 8 m is
(a) 12.56 m² (b) 25.12 m² (c) 50.24 m² (d) 200.96 m²
- 23.** Area of a circle with diameter ' m ' radius ' n ' and circumference ' p ' is
(a) $2\pi n$ (b) πm^2 (c) πp^2 (d) πn^2
- 24.** A table top is semicircular in shape with diameter 2.8 m. Area of this table top is
(a) 3.08 m² (b) 6.16 m² (c) 12.32 m² (d) 24.64 m²
- 25.** If $1\text{m}^2 = x\text{mm}^2$, then the value of x is
(a) 1000 (b) 10000 (c) 100000
(d) 1000000
- 26.** If p squares of each side 1mm makes a square of side 1cm, then p is equal to
(a) 10 (b) 100 (c) 1000 (d) 10000
- 27.** 12 m² is the area of
(a) a square with side 12 m
(b) 12 squares with side 1m each
(c) 3 squares with side 4 m each
(d) 4 squares with side 3 m each
- 28.** If each side of a rhombus is doubled, how much will its area increase?
(a) 1.5 times (b) 2 times (c) 3 times (d) 4 times
- 29.** If the sides of a parallelogram are increased to twice its original lengths, how much will the perimeter of the new parallelogram?
(a) 1.5 times (b) 2 times (c) 3 times (d) 4 times
- 30.** If radius of a circle is increased to twice its original length, how much will the area of the circle increase?
(a) 1.4 times (b) 2 times (c) 3 times (d) 4 times
- 31.** What will be the area of the largest square that can be cut out of a circle of radius 10 cm?
(a) 100 cm² (b) 200 cm² (c) 300 cm² (d) 400 cm²

Thirty-seven specialists including artists, stone cutters, engineers, architects, calligraphers, and inlayers designed the Taj Mahal and supervised the 20,000 workers who built it.

This section of flooring from a terrace at the Taj Mahal is inlaid with white marble and red sandstone tiles.

What geometric shapes do you see in the pattern in the floor?

The design and construction of the terrace must have involved measuring lengths and finding areas.



- 32.** What is the radius of the largest circle that can be cut out of the rectangle measuring 10 cm in length and 8 cm in breadth?
 (a) 4 cm (b) 5 cm (c) 8 cm (d) 10 cm
- 33.** The perimeter of the figure ABCDEFGHIJ is
 (a) 60 cm (b) 30 cm (c) 40 cm (d) 50 cm

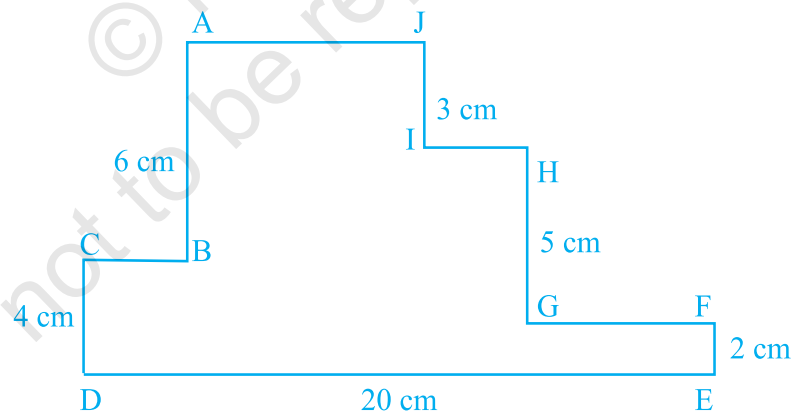

Fig. 9.23

- 34.** The circumference of a circle whose area is $81\pi r^2$, is
 (a) $9\pi r$ (b) $18\pi r$ (c) $3\pi r$ (d) $81\pi r$
- 35.** The area of a square is 100 cm^2 . The circumference (in cm) of the largest circle cut of it is
 (a) 5π (b) 10π (c) 15π (d) 20π

36. If the radius of a circle is tripled, the area becomes
 (a) 9 times (b) 3 times (c) 6 times (d) 30 times
37. The area of a semicircle of radius $4r$ is
 (a) $8\pi r^2$ (b) $4\pi r^2$ (c) $12\pi r^2$ (d) $2\pi r^2$

In Questions 38 to 56, fill in the blanks to make the statements true.

38. Perimeter of a regular polygon = length of one side \times _____.

39. If a wire in the shape of a square is rebent into a rectangle, then the _____ of both shapes remain same, but _____ may vary.

40. Area of the square MNOP of Fig. 9.24 is 144 cm^2 . Area of each triangle is _____.

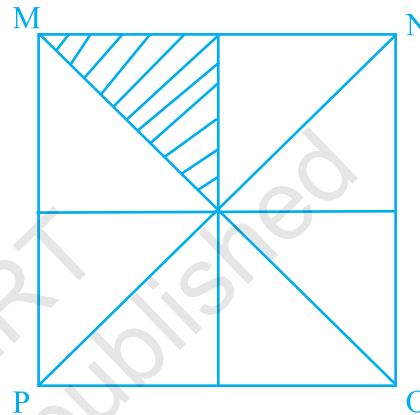

Fig. 9.24

41. In Fig. 9.25, area of parallelogram BCEF is _____ cm^2 where ACDF is a rectangle.

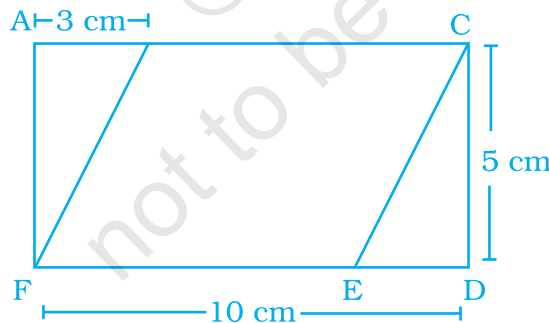

Fig. 9.25

42. To find area, any side of a parallelogram can be chosen as _____ of the parallelogram.
43. Perpendicular dropped on the base of a parallelogram from the opposite vertex is known as the corresponding _____ of the base.
44. The distance around a circle is its _____.

45. Ratio of the circumference of a circle to its diameter is denoted by symbol _____.
46. If area of a triangular piece of cardboard is 90 cm^2 , then the length of altitude corresponding to 20 cm long base is _____ cm.
47. Value of π is _____ approximately.
48. Circumference 'C' of a circle can be found by multiplying diameter 'd' with _____.
49. Circumference 'C' of a circle is equal to $2\pi \times$ _____.
50. $1 \text{ m}^2 =$ _____ cm^2 .
51. $1 \text{ cm}^2 =$ _____ mm^2 .
52. 1 hectare = _____ m^2 .
53. Area of a triangle = $\frac{1}{2}$ base \times _____.
54. $1 \text{ km}^2 =$ _____ m^2 .
55. Area of a square of side 6 m is equal to the area of _____ squares of each side 1 cm.
56. $10 \text{ cm}^2 =$ _____ m^2 .

In Questions 57 to 72, state whether the statements are True or False.

57. In Fig. 9.26, perimeter of (ii) is greater than that of (i), but its area is smaller than that of (i).

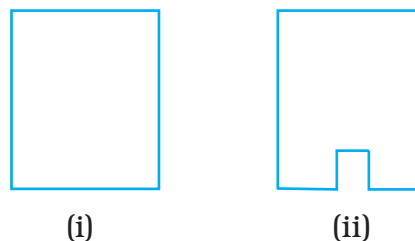
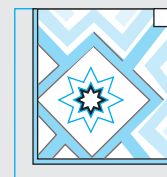

Fig. 9.26

Some of the designs created on the walls of the Taj Mahal can be made using rectangles and triangles. You can use what you know about the area of parallelograms to find the area of triangles.



58. In Fig. 9.27,
 (a) area of (i) is the same as the area of (ii).

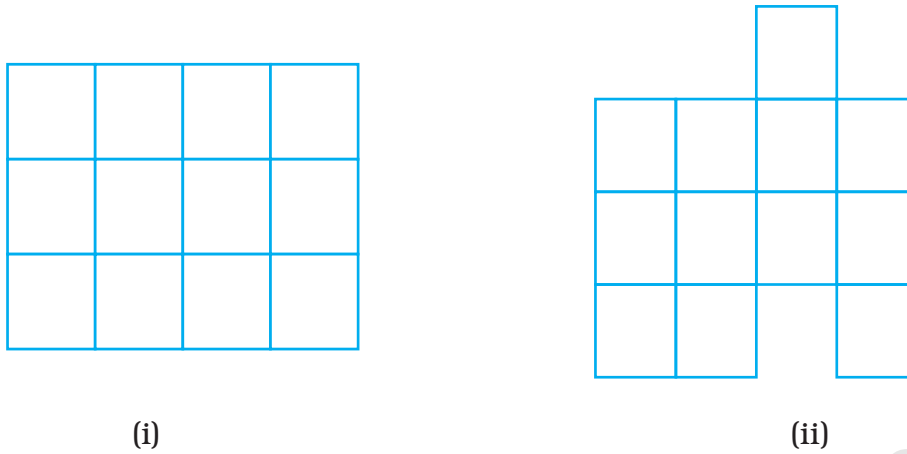

Fig. 9.27

- (b) Perimeter of (ii) is the same as (i).
 (c) If (ii) is divided into squares of unit length, then its area is 13 unit squares.
 (d) Perimeter of (ii) is 18 units.
59. If perimeter of two parallelograms are equal, then their areas are also equal.
60. All congruent triangles are equal in area.
61. All parallelograms having equal areas have same perimeters.
 Observe all the four triangles FAB, EAB, DAB and CAB as shown in Fig. 9.28:

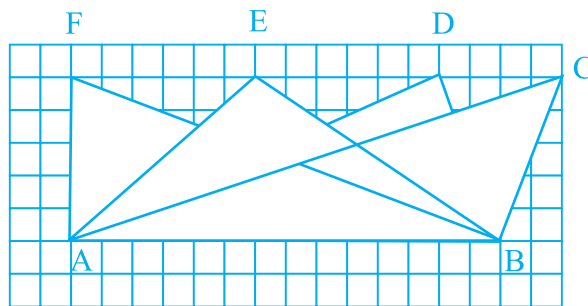

Fig. 9.28

Now answer Questions 62 to 65:

- 62. All triangles have the same base and the same altitude.
- 63. All triangles are congruent.
- 64. All triangles are equal in area.
- 65. All triangles may not have the same perimeter.
- 66. In Fig. 9.29 ratio of the area of triangle ABC to the area of triangle ACD is the same as the ratio of base BC of triangle ABC to the base CD of triangle ACD.

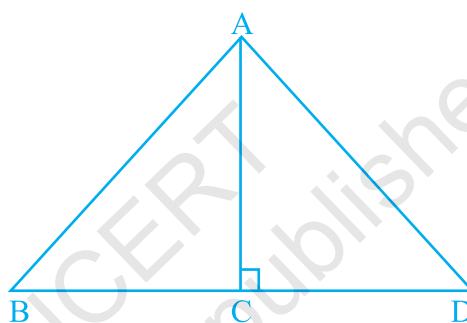

Fig. 9.29

- 67. Triangles having the same base have equal area.
- 68. Ratio of circumference of a circle to its radius is always $2\pi : 1$.
- 69. 5 hectare = 500 m²
- 70. An increase in perimeter of a figure always increases the area of the figure.
- 71. Two figures can have the same area but different perimeters.
- 72. Out of two figures if one has larger area, then its perimeter need not to be larger than the other figure.
- 73. A hedge boundary needs to be planted around a rectangular lawn of size 72 m \times 18 m. If 3 shrubs can be planted in a metre of hedge, how many shrubs will be planted in all?

74. People of Khejadli village take good care of plants, trees and animals. They say that plants and animals can survive without us, but we can not survive without them. Inspired by her elders Amrita marked some land for her pets (camel and ox) and plants. Find the ratio of the areas kept for animals and plants to the living area.

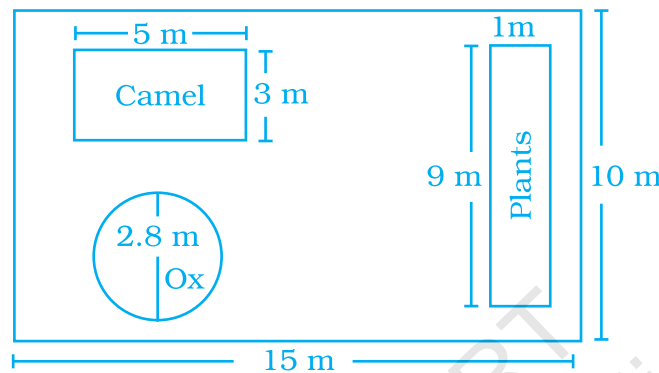
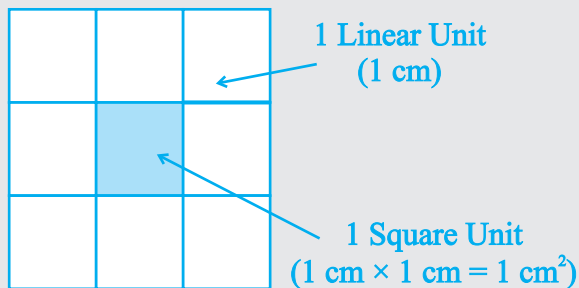

Fig. 9.30

75. The perimeter of a rectangle is 40 m. Its length is four metres less than five times its breadth. Find the area of the rectangle.
76. A wall of a room is of dimensions 5 m \times 4 m. It has a window of dimensions 1.5 m \times 1m and a door of dimensions 2.25 m \times 1m. Find the area of the wall which is to be painted.
77. Rectangle MNOP is made up of four congruent rectangles (Fig. 9.31). If the area of one of the rectangles is 8 m² and breadth is 2 m, then find the perimeter of MNOP.

Square units are also used to measure area in the metric system. Since each small square is 1 cm by 1 cm, it has an area of **1 square centimetre (1 cm²)**.



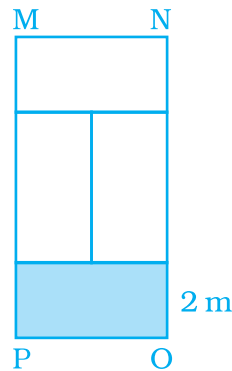

Fig. 9.31

78. In Fig. 9.32, area of $\triangle AFB$ is equal to the area of parallelogram ABCD. If altitude EF is 16 cm long, find the altitude of the parallelogram to the base AB of length 10 cm. What is the area of $\triangle DAO$, where O is the mid point of DC?

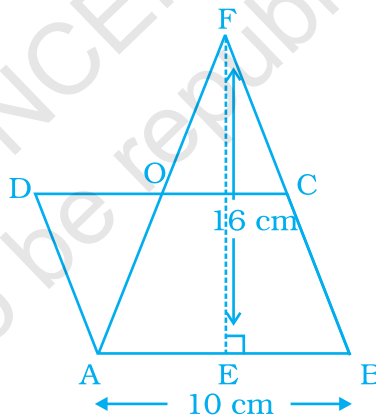

Fig. 9.32

Did You Know

Area is expressed in square units, such as square metre or square centimetres. You can abbreviate square units by writing the abbreviation for the unit followed by a power raised 2. For example, an abbreviation for square metre is m^2 .

Volume is expressed in cubic units. You can abbreviate cubic units by writing the abbreviation for the unit followed by a power raised 3. For example, an abbreviation for cubic centimetres is cm^3 .

79. Ratio of the area of ΔWXY to the area of ΔWZY is 3 : 4 (Fig. 9.33). If the area of ΔWXZ is 56 cm^2 and $WY = 8 \text{ cm}$, find the lengths of XY and YZ .

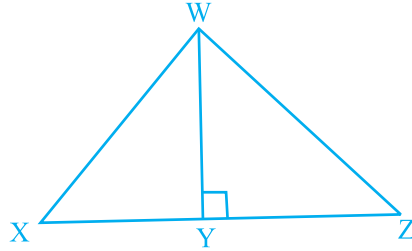

Fig. 9.33

80. Rani bought a new field that is next to one she already owns (Fig. 9.34). This field is in the shape of a square of side 70 m. She makes a semi circular lawn of maximum area in this field.
- Find the perimeter of the lawn.
 - Find the area of the square field excluding the lawn.



Fig. 9.34

81. In Fig. 9.35, find the area of parallelogram ABCD if the area of shaded triangle is 9 cm^2 .

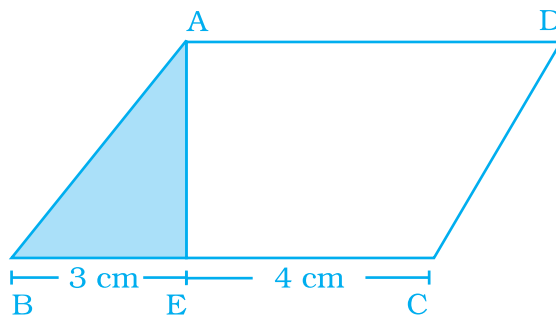

Fig. 9.35

82. Pizza factory has come out with two kinds of pizzas. A square pizza of side 45 cm costs ₹ 150 and a circular pizza of diameter 50 cm costs ₹160 (Fig. 9.36). Which pizza is a better deal?

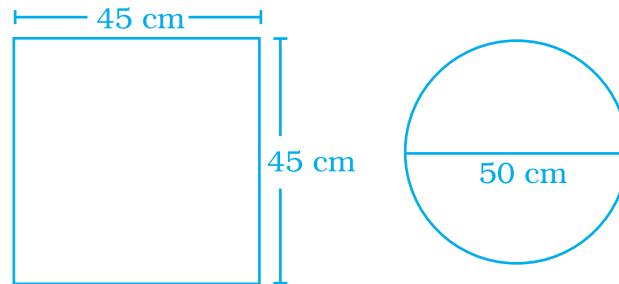

Fig. 9.36

83. Three squares are attached to each other as shown in Fig. 9.37. Each square is attached at the mid point of the side of the square to its right. Find the perimeter of the complete figure.



Fig. 9.37

Visual displays can help you relate ideas and organise information. Copy and extend the concept map to connect ideas you have learned about area. Add on units of measure, formulas, and notes about relationships.

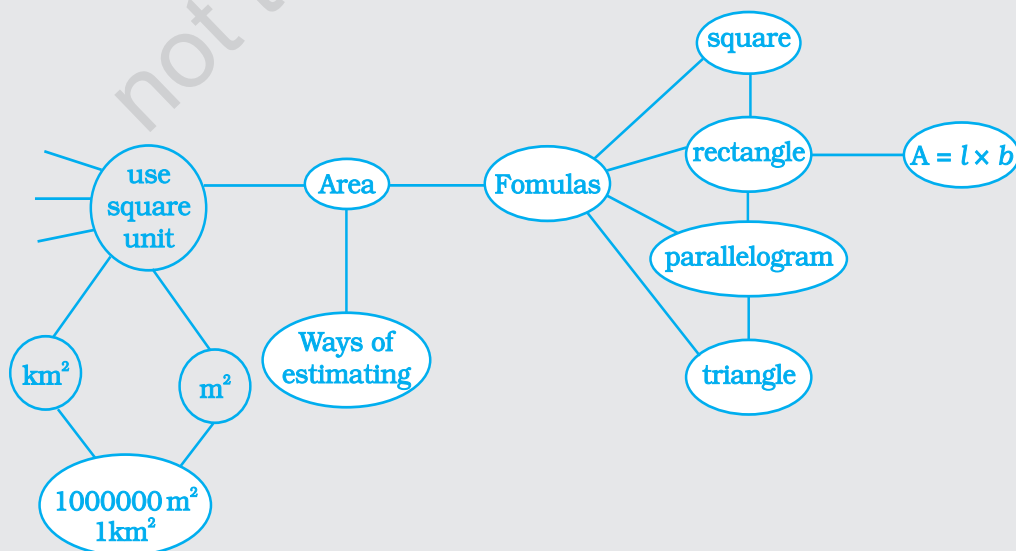

84. In Fig. 9.38, ABCD is a square with AB = 15 cm. Find the area of the square BDFE.

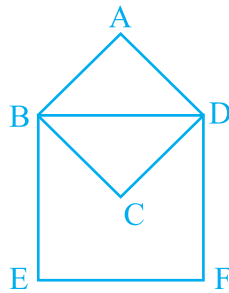

Fig. 9.38

85. In the given triangles of Fig. 9.39, perimeter of $\triangle ABC$ = perimeter of $\triangle PQR$. Find the area of $\triangle ABC$.

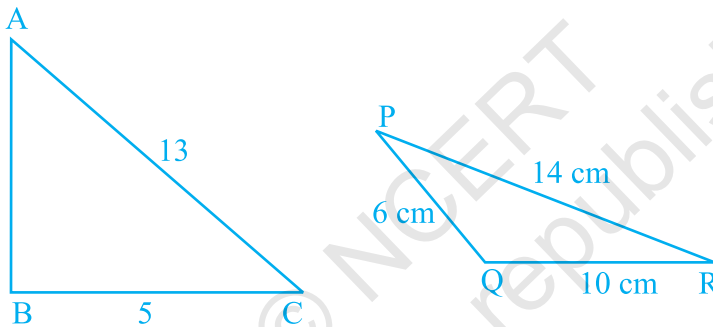

Fig. 9.39

86. Altitudes MN and MO of parallelogram MGHK are 8 cm and 4 cm long respectively (Fig. 9.40). One side GH is 6 cm long. Find the perimeter of MGHK.

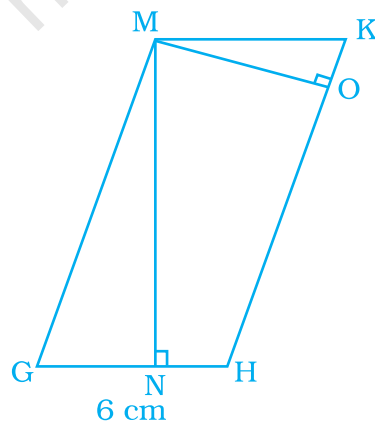

Fig. 9.40

87. In Fig. 9.41, area of ΔPQR is 20 cm^2 and area of ΔPQS is 44 cm^2 . Find the length RS , if PQ is perpendicular to QS and QR is 5 cm .

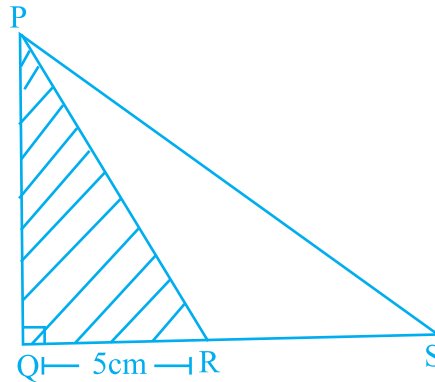

Fig. 9.41

88. Area of an isosceles triangle is 48 cm^2 . If the altitudes corresponding to the base of the triangle is 8 cm , find the perimeter of the triangle.
89. Perimeter of a parallelogram shaped land is 96 m and its area is 270 square metres. If one of the sides of this parallelogram is 18 m , find the length of the other side. Also, find the lengths of altitudes l and m (Fig. 9.42).

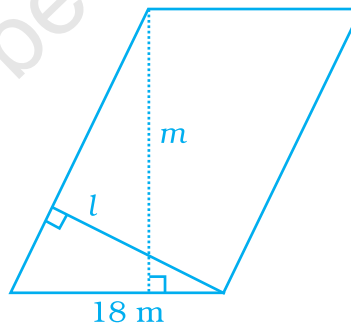
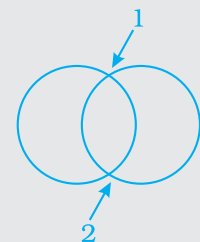

Fig. 9.42

Circles

What is the maximum number of times that six circles of the same size can intersect? To find the answer, start by drawing two circles that are of the same size. What is the greatest number of times they can intersect? Add another circle, and another, and so on.



90. Area of a triangle PQR right-angled at Q is 60 cm^2 (Fig. 9.43). If the smallest side is 8 cm long, find the length of the other two sides.

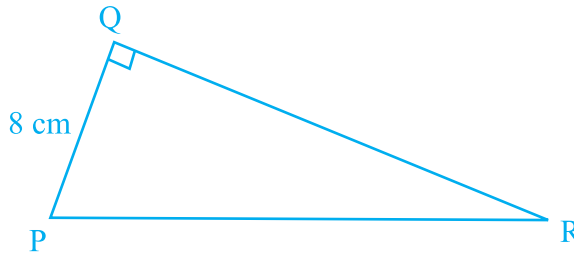

Fig. 9.43

91. In Fig. 9.44 a rectangle with perimeter 264 cm is divided into five congruent rectangles. Find the perimeter of one of the rectangles.

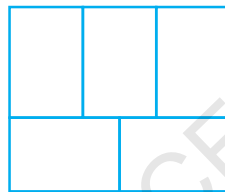

Fig. 9.44

92. Find the area of a square inscribed in a circle whose radius is 7 cm (Fig. 9.45).

[Hint: Four right-angled triangles joined at right angles to form a square]

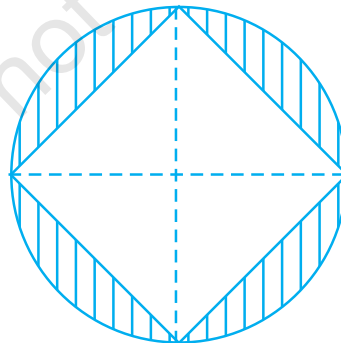

Fig. 9.45

93. Find the area of the shaded portion in question 92.

In Questions 94 to 97 find the area enclosed by each of the following figures :

94.

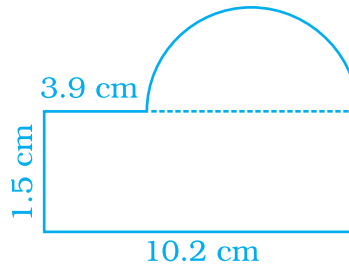

Fig. 9.46

95.

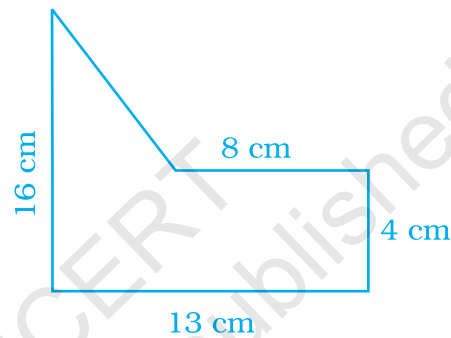

Fig. 9.47

96.

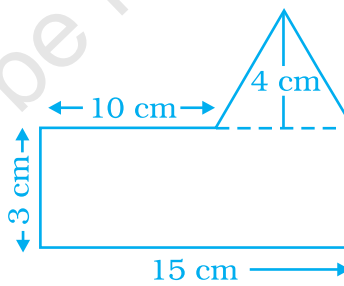

Fig. 9.48

97.

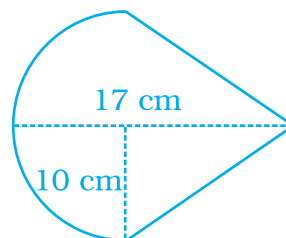

Fig. 9.49

In Questions 98 and 99 find the areas of the shaded region:

98.

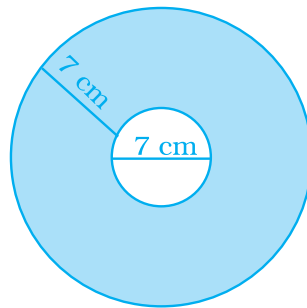

Fig. 9.50

99.

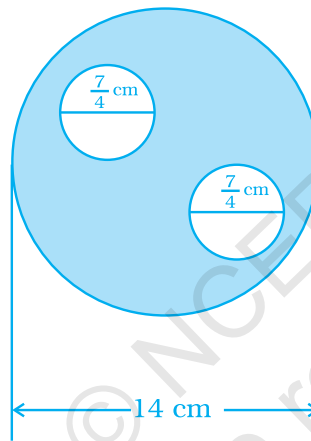

Fig. 9.51

100. A circle with radius 16 cm is cut into four equal parts and rearranged to form another shape as shown in Fig. 9.52:

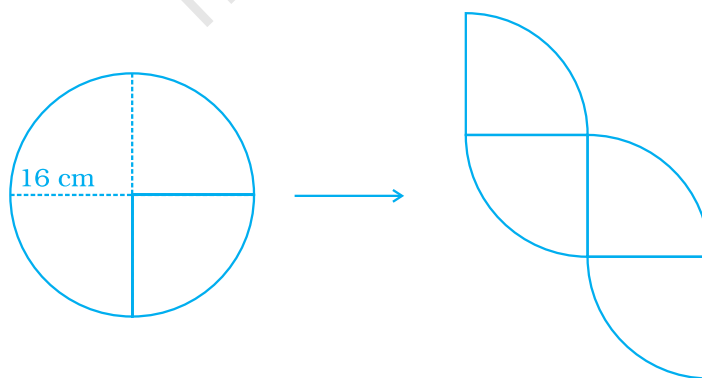

Fig. 9.52

Does the perimeter change? If it does change, by how much does it increase or decrease?

- 101.** A large square is made by arranging a small square surrounded by four congruent rectangles as shown in Fig. 9.53. If the perimeter of each of the rectangle is 16 cm, find the area of the large square.

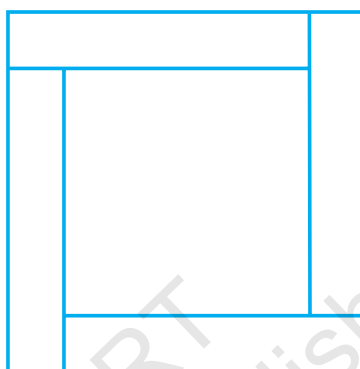
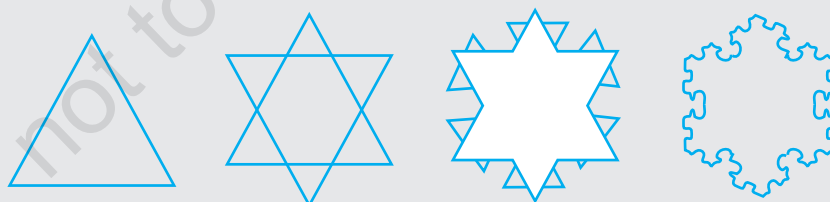

Fig. 9.53

The figures show how a fractal called the Koch snowflake is formed. It is constructed by first drawing an equilateral triangle. Then triangles with sides one-third the length of the original sides are added to the middle of each side. The second step is then repeated over and over again.



The area and perimeter of each figure is larger than that of the one before it. However, the area of any figure is never greater than the area of the shaded box, while the perimeters increase without bound.

- 102.** ABCD is a parallelogram in which AE is perpendicular to CD (Fig. 9.54). Also $AC = 5$ cm, $DE = 4$ cm, and the area of $\triangle AED = 6$ cm². Find the perimeter and area of ABCD.

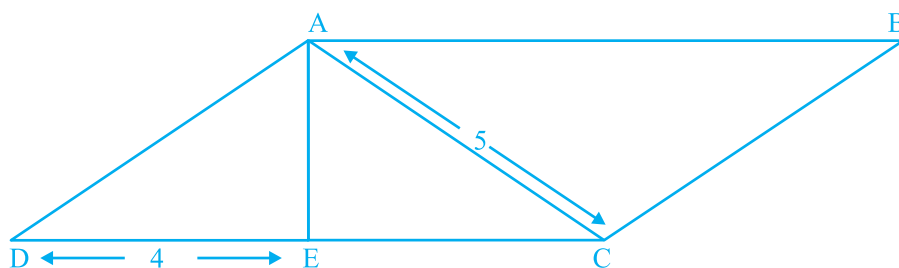

Fig. 9.54

- 103.** Ishika has designed a small oval race track for her remote control car. Her design is shown in the figure 9.55. What is the total distance around the track? Round your answer to the nearest whole cm.

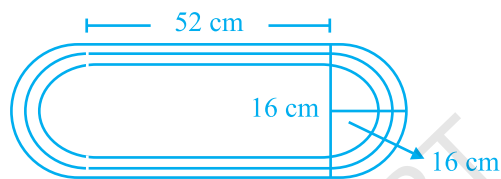
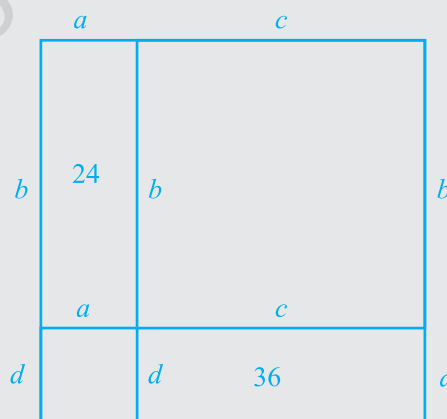
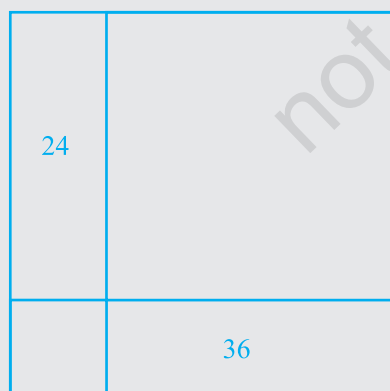

Fig. 9.55

Shape up

Rectangles

The square below has been divided into four rectangles. The areas of two of the rectangles are given. If the length of each of the segments in the diagram is an integer, what is the area of the original square?



(**Hint:** Remember $a + c = b + d$)

Use different lengths and a different answer to create your own version of this puzzle.

- 104.** A table cover of dimensions 3 m 25 cm \times 2 m 30 cm is spread on a table. If 30 cm of the table cover is hanging all around the table, find the area of the table cover which is hanging outside the top of the table. Also find the cost of polishing the table top at ₹ 16 per square metre.
- 105.** The dimensions of a plot are 200 m \times 150 m. A builder builds 3 roads which are 3 m wide along the length on either side and one in the middle. On either side of the middle road he builds houses to sell. How much area did he get for building the houses?
- 106.** A room is 4.5 m long and 4 m wide. The floor of the room is to be covered with tiles of size 15 cm by 10 cm. Find the cost of covering the floor with tiles at the rate of ₹ 4.50 per tile.
- 107.** Find the total cost of wooden fencing around a circular garden of diameter 28 m, if 1m of fencing costs ₹ 300.
- 108.** Priyanka took a wire and bent it to form a circle of radius 14 cm. Then she bent it into a rectangle with one side 24 cm long. What is the length of the wire? Which figure encloses more area, the circle or the rectangle?
- 109.** How much distance, in metres, a wheel of 25 cm radius will cover if it rotates 350 times?



Revise

- Does your solution answer the question?

When you think you have solved a problem, think again. Your answer may not really be the solution to the problem. For example, you may solve an equation to find the value or a variable, but to find the answer the problem is asking for, the value of the variable may need to be substituted into an expression.

- 110.** A circular pond is surrounded by a 2 m wide circular path. If outer circumference of circular path is 44 m, find the inner circumference of the circular path. Also find area of the path.
- 111.** A carpet of size 5 m × 2 m has 25 cm wide red border. The inner part of the carpet is blue in colour (Fig. 9.56). Find the area of blue portion. What is the ratio of areas of red portion to blue portion?

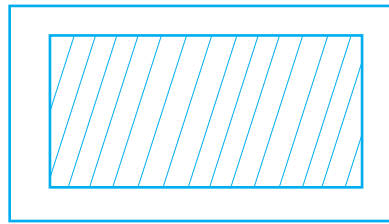

Fig. 9.56

- 112.** Use the Fig. 9.57 showing the layout of a farm house:

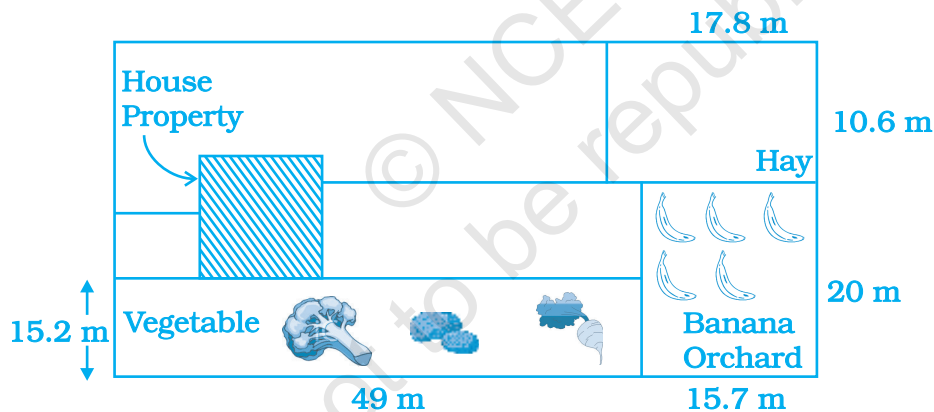

Fig. 9.57

- What is the area of land used to grow hay?
- It costs ₹ 91 per m^2 to fertilise the vegetable garden. What is the total cost?
- A fence is to be enclosed around the house. The dimensions of the house are 18.7 m × 12.6 m. At least how many metres of fencing are needed?
- Each banana tree required 1.25 m^2 of ground space. How many banana trees can there be in the orchard?

113. Study the layout given below in Fig. 9.58 and answer the questions:

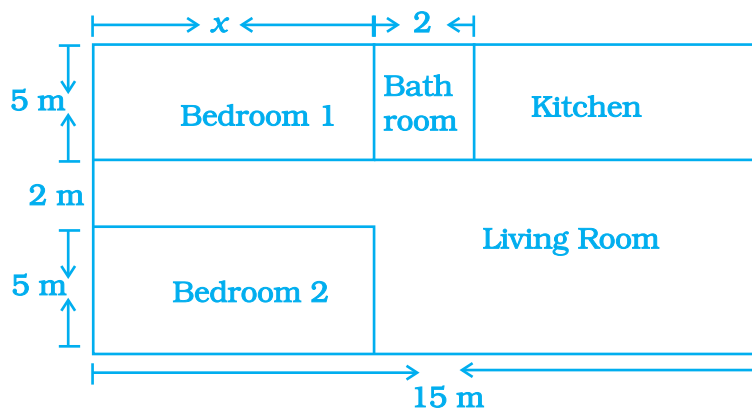

Fig. 9.58

- Write an expression for the total area covered by both the bedrooms and the kitchen.
 - Write an expression to calculate the perimeter of the living room.
 - If the cost of carpeting is ₹ 50/m², write an expression for calculating the total cost of carpeting both the bedrooms and the living room.
 - If the cost of tiling is ₹ 30/m², write an expression for calculating the total cost of floor tiles used for the bathroom and kitchen floors.
 - If the floor area of each bedroom is 35 m², then find x .
114. A 10 m long and 4 m wide rectangular lawn is in front of a house. Along its three sides a 50 cm wide flower bed is there as shown in Fig. 9.59. Find the area of the remaining portion.

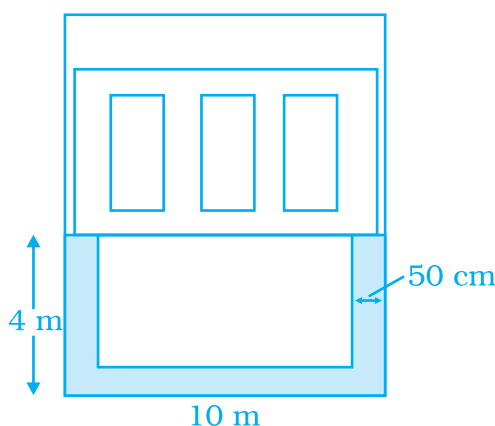

Fig. 9.59

- 115.** A school playground is divided by a 2 m wide path which is parallel to the width of the playground, and a 3 m wide path which is parallel to the length of the ground (Fig. 9.60). If the length and width of the playground are 120 m and 80 m respectively, find the area of the remaining playground.

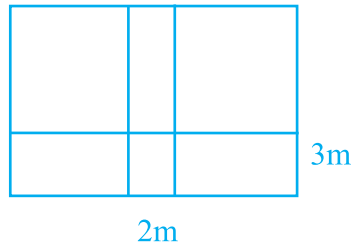

Fig. 9.60

- 116.** In a park of dimensions 20 m × 15 m, there is a L shaped 1m wide flower bed as shown in Fig. 9.61. Find the total cost of manuring for the flower bed at the rate of Rs 45 per m².

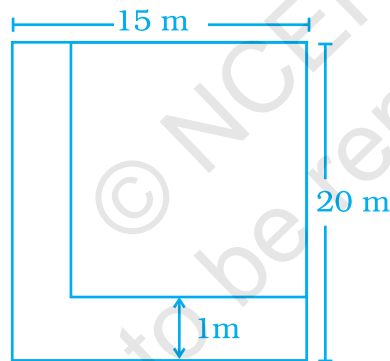

Fig. 9.61

- 117.** Dimensions of a painting are 60 cm × 38 cm. Find the area of the wooden frame of width 6 cm around the painting as shown in Fig. 9.62.

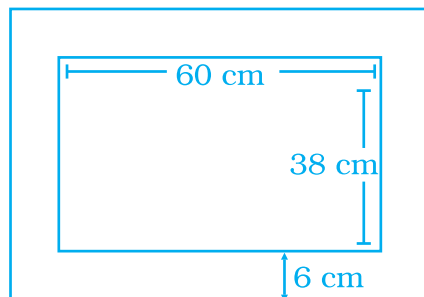

Fig. 9.62

- 118.** A design is made up of four congruent right triangles as shown in Fig. 9.63. Find the area of the shaded portion.

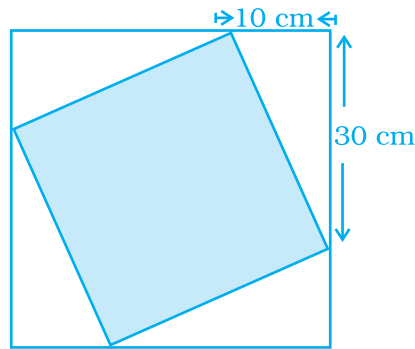

Fig. 9.63

- 119.** A square tile of length 20 cm has four quarter circles at each corner as shown in Fig. 9.64(i). Find the area of shaded portion. Another tile with same dimensions has a circle in the centre of the tile [Fig. 9.64 (ii)]. If the circle touches all the four sides of the square tile, find the area of the shaded portion. In which tile, area of shaded portion will be more? (Take $\pi = 3.14$)

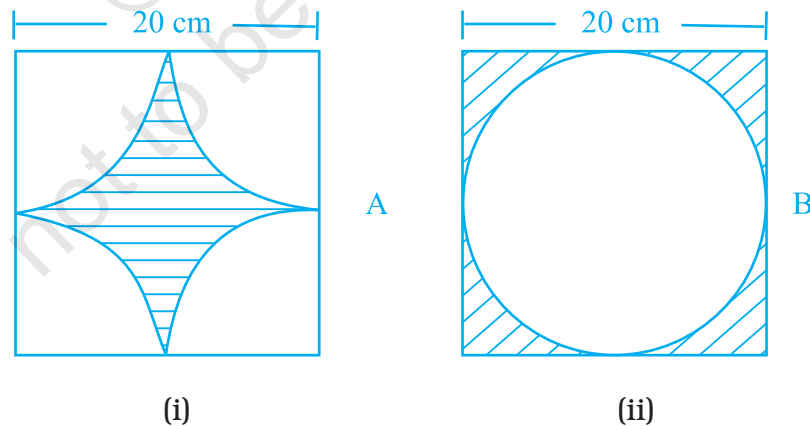

Fig. 9.64

- 120.** A rectangular field is 48 m long and 12 m wide. How many right triangular flower beds can be laid in this field, if sides including the right angle measure 2 m and 4 m, respectively?

- 121.** Ramesh grew wheat in a rectangular field that measured 32 metres long and 26 metres wide. This year he increased the area for wheat by increasing the length but not the width. He increased the area of the wheat field by 650 square metres. What is the length of the expanded wheat field?
- 122.** In Fig. 9.65, triangle AEC is right-angled at E, B is a point on EC, BD is the altitude of triangle ABC, AC = 25 cm, BC = 7 cm and AE = 15 cm. Find the area of triangle ABC and the length of DB.

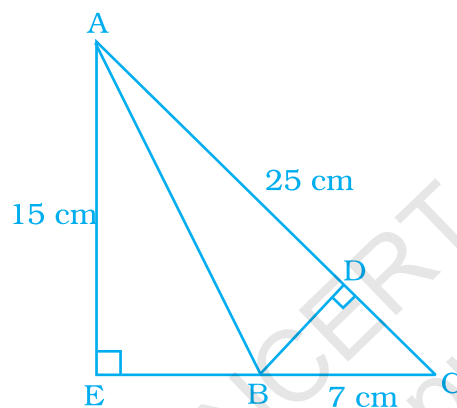

Fig. 9.65

123.



Can you help me to figure out how many pieces of $1.5\text{ cm} \times 2\text{ cm}$ chocolate can I cut from a $18\text{ cm} \times 18\text{ cm}$ sheet of chocolate?



I Raju facing a problem. Can you help me?



What is the problem Raju?



Hmm...., Let us take the help of our friends to find the number of pieces!!

124. Calculate the area of shaded region in Fig. 9.66, where all of the short line segments are at right angles to each other and 1 cm long.

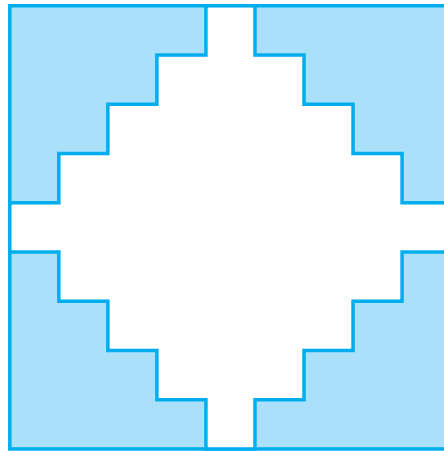

Fig. 9.66

125. The plan and measurement for a house are given in Fig. 9.67. The house is surrounded by a path 1 m wide.

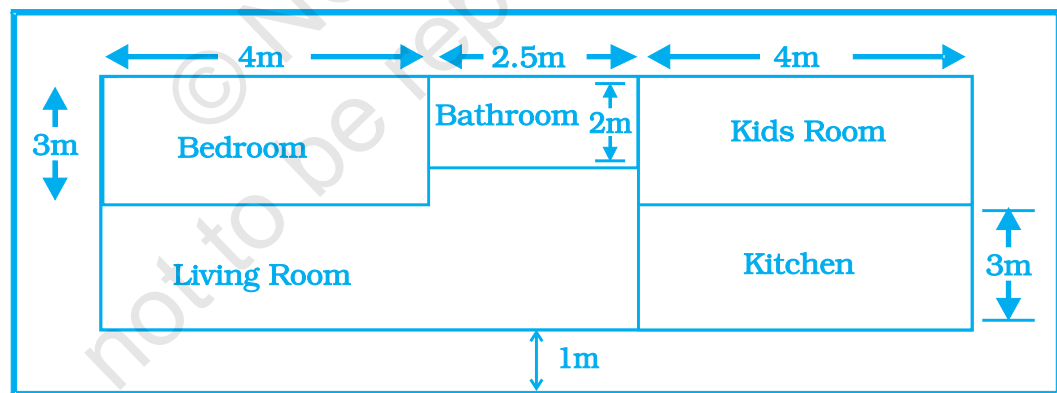

Fig. 9.67

Find the following:

- Cost of paving the path with bricks at rate of ₹ 120 per m^2 .
- Cost of wooden flooring inside the house except the bathroom at the cost of ₹ 1200 per m^2 .
- Area of Living Room.

126. Architects design many types of buildings. They draw plans for houses, such as the plan shown in Fig. 9.68:

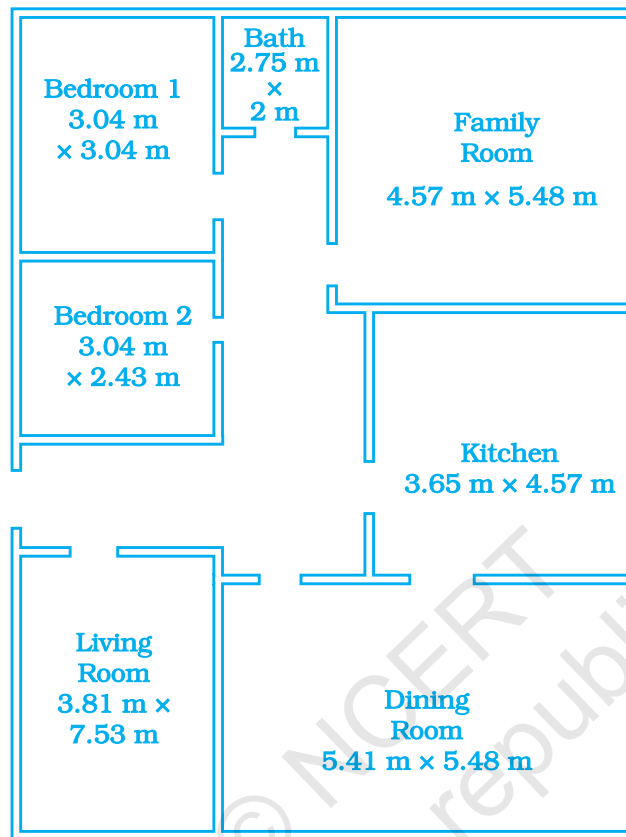

Fig. 9.68

An architect wants to install a decorative moulding around the ceilings in all the rooms. The decorative moulding costs ₹ 500/metre.

- (a) Find how much moulding will be needed for each room.
- (i) family room (ii) living room (iii) dining room
(iv) bedroom 1 (v) bedroom 2

(b) The carpet costs ₹ 200/m². Find the cost of carpeting each room.

(c) What is the total cost of moulding for all the five rooms.

127. ABCD is a given rectangle with length as 80 cm and breadth as 60 cm. P, Q, R, S are the mid points of sides AB, BC, CD, DA respectively. A circular *rangoli* of radius 10 cm is drawn at the centre as shown in Fig. 9.69. Find the area of shaded portion.

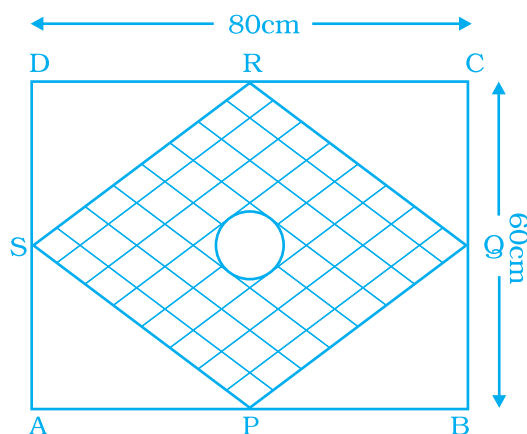

Fig. 9.69

- 128.** 4 squares each of side 10 cm have been cut from each corner of a rectangular sheet of paper of size 100 cm \times 80 cm. From the remaining piece of paper, an isosceles right triangle is removed whose equal sides are each of 10 cm length. Find the area of the remaining part of the paper.
- 129.** A dinner plate is in the form of a circle. A circular region encloses a beautiful design as shown in Fig. 9.70. The inner circumference is 352 mm and outer is 396 mm. Find the width of circular design.

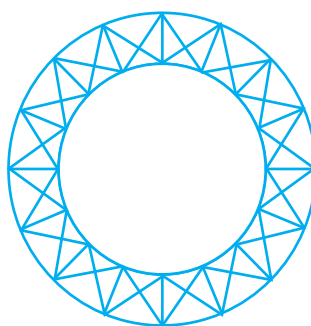

Fig. 9.70

- 130.** The moon is about 384000 km from earth and its path around the earth is nearly circular. Find the length of path described by moon in one complete revolution. (Take $\pi = 3.14$)

- 131.** A photograph of Billiard/Snooker table has dimensions as $\frac{1}{10}$ th of its actual size as shown in Fig. 9.71:

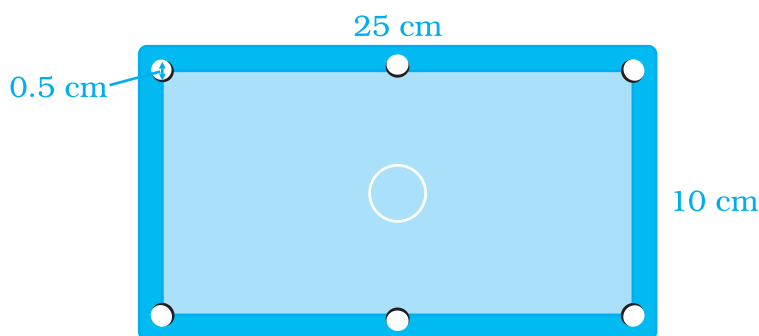

Fig. 9.71

The portion excluding six holes each of diameter 0.5 cm needs to be polished at rate of ₹ 200 per m^2 . Find the cost of polishing.

(D) Applications

For (1) –(4): For the dimensions of the field / court refer the diagram given at the end of the unit.

1. Find the dimensions of a Basket Ball court.
 - (i) Calculate the perimeter of the court.
 - (ii) Calculate the total area of the court.
 - (iii) Find the total area of the bigger central circle of the court.
 - (iv) Find the area of the smaller central circle.
 - (v) Find the difference of areas found in part (iii) and (iv).

2. Find the dimensions of a Badminton court.
 - (i) Calculate the perimeter of the court.
 - (ii) Calculate the total area of the court.
 - (iii) Find the total area of any one side boundaries of the court.
 - (iv) Find the area of a left service court.

3. In a foot ball field, calculate the
 - (i) total area of the 2 goal posts.
 - (ii) total area covered by the field.
 - (iii) the perimeter of the field.
4. In a hockey field, calculate the
 - (i) area included inside the shooting circles.
 - (ii) the perimeter of Hockey ground.
5. Complete the following data by using the formula for circumference of a circle.

$$\text{Circumference of a circle} = 2\pi r$$

r = radius of the circle

	Radius	Diameter	Circumference
Foot ball			71 cm
Basket ball		24.8 cm	
Cricket ball			23 cm
Volley ball	10.3 cm		
Hockey ball			22.4 cm
Lawn Tennis ball		6.35 cm	
Shot put	65 mm		

(Circumference of a ball is used in the sense of circumference of the circle with the same radius).

6. Observe the two rectangles given in Fig. 9.72:
 Rectangle A has greater area but its perimeter is less than rectangle B.

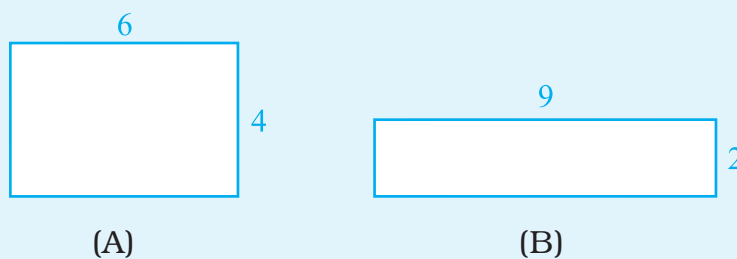

Fig. 9.72

Now draw the following pair of rectangles:

- (i) having same area but different perimeter.
- (ii) having same perimeter but different areas.
- (iii) One has larger area but smaller perimeter than other.
- (iv) Area of one rectangle is three times the area of other rectangle but both have the same perimeters.

7. Puzzle

In this puzzle, called a “Squared square,” squares of different sizes are contained within one big rectangle. The goal is to find out the sizes of the squares with the questions marks. By comparing known length of lines make some deductions to find out the sizes that are missing. Each number stands for the length of the side in that square.

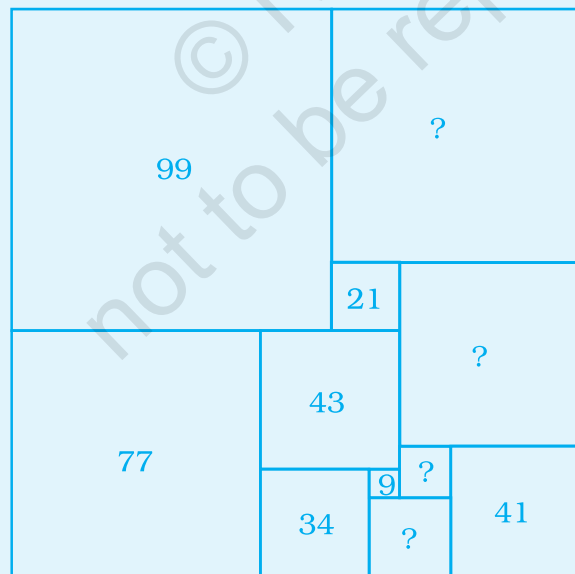
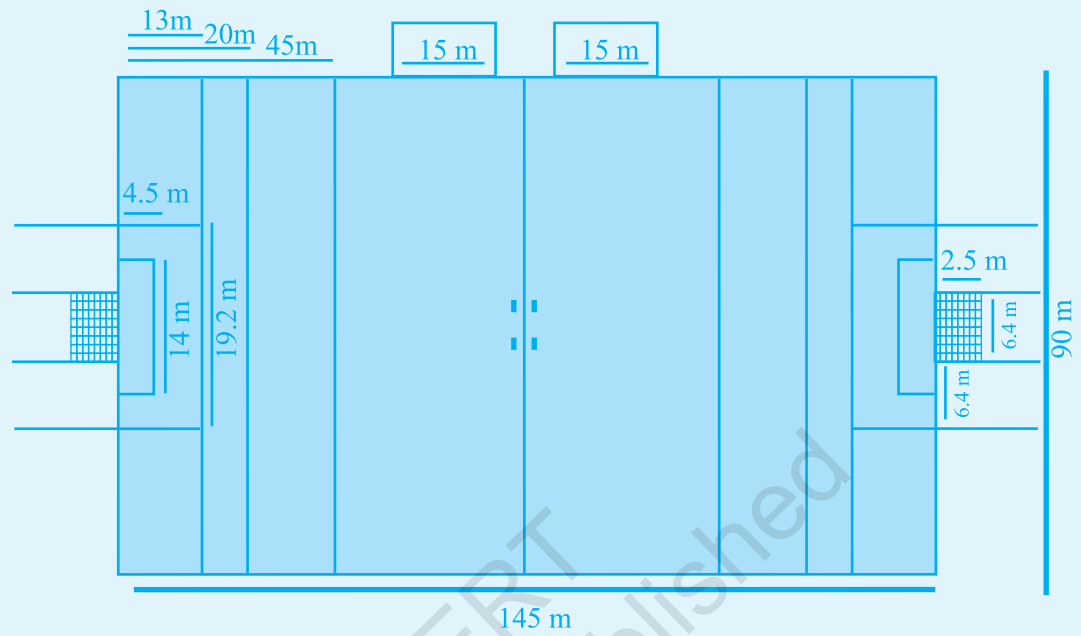

Fig. 9.73

For Activity Q.3. Foot ball Field



For Activity Q.4. Hockey Ground

