

**MARKING SCHEME  
SAMPLE PAPER  
CLASS-XII  
AUTO SHOP REPAIR AND PRACTICE (628)**

**(Group A)**

Question No.	Answers	Marks
Q1	D	[1]
Q2	A	[1]
Q3	A	[1]
Q4	C	[1]
Q5	C	[1]
Q6	D	[1]
Q7	B	[1]
Q8	A	[1]
Q9	A	[1]
Q10	D	[1]
Q11	A	[1]
Q12	B	[1]

**(Group B)**

Question No.	Answers	Marks
Q13	1)Prick punch 2)spanner	[2]
Q14	LEAST COUNT = PITCH / TOTAL NO OF DIVISION IN CIRCULAR SCALE. $= 0.5 \text{ MM} / 50 = 0.001 \text{ MM}$	[2]
Q15	a) Shock absorbers improve riding comfort.	[2]

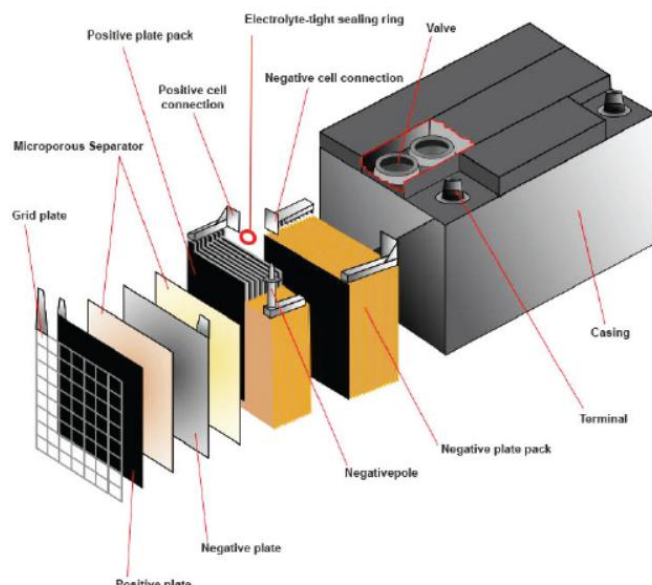
	<p>b) It keeps the tyres evenly connected with the road and maintaining a vertical load on the tyres.</p> <p>c) It Reduces the effect of shock forces to the vehicle</p>	
Q16	<p>Following steps are involved in inspecting accidental car</p> <p>a)Get Vehicle details</p> <p>b)A small diagram indicating the area of damage. Different impacts are marked separately; primary impacts are indicated with 'XXX' and secondary impacts with 'OOO.'</p> <p>c)The repair work required to get the vehicle back to its pre-accident condition: new parts needed, repairs to panels, any specialist work including geometry check and jigs, and a breakdown of the costs involved is identified.</p>	[2]
Q17	<p>Hooke's joint is a type of Cross or spider type joint. It is most common type of universal joint widely used in automobiles because of the fact that it is simple in construction and reasonable efficient at small angles (generally <b>up to 20° angle</b>) of up and down movement of propeller shaft.</p>	[2]
Q18		
Q19	<p>The chemical used in automotive batteries is a solution (liquid combination) of <b>36% sulphuric acid and 64% water</b>. This electrolyte is used for both lead-antimony and lead calcium (maintenance free) batteries. The chemical symbol for this sulphuric acid solution is <b><math>H_2SO_4</math></b></p> <p><b>H = symbol for hydrogen</b> (the subscript 2 means that there are two atoms of hydrogen)</p> <p><b>S = symbol for sulphur</b></p>	[2]

	<b>O = symbol for oxygen</b> (the subscript 4 indicates that there are four atoms of oxygen)	
--	--	--

**(Group C)**

Question No.	Answers	Marks
Q20	<p>Heating ventilation and air conditioning. It is the technology for indoor and automotive ambient comfort. It facilitates in managing pleasant climate inside the cabin by controlling the degree of hotness coolness</p> <p>It comprises five major components.</p> <ol style="list-style-type: none"> <li>1) Evaporator</li> <li>2) Compressor</li> <li>3) Condenser</li> <li>4) Receiver / Driver</li> <li>5) Expansion device</li> </ol>	[3]
Q21	<p>It is such an instrument used to make a cyclically moving object appear to be slow moving or stationary.</p> <p>It consists of either a rotating disk with slots or a holes or a lamp such as a flash tube.</p> <p>It produces repeating flash of light the rate of stroboscopes is adjustable at different frequencies.</p> <p>If we observe an object with stroboscope at its vibration frequency it appears to be stationary</p> <p>Stroboscope is also used to measure frequency.</p> <p>It is used for studying of rotating, reciprocating oscillating or vibrating objects.</p> <p>A stroboscope is used set the ignition timing of internal combustion engine called timing light.</p>	[3]
Q22	<p>A bevel gauge is an adjustable gauge for setting and transferring angles. The handle is usually made of wood or plastic or steel and is connected to a metal blade with a thumb screw or wing nut. The blade pivots and can be locked at any angle by loosening or tightening the thumb screw. Gauge is mainly used to measure of angle of valve face, valve seat. The straight edge is used to check the distortion of plain surfaces like cylinder head, cylinder block</p>	[3]

	 <p>The diagram shows a spirit level with four labeled parts: 'Blade' pointing to the long metal strip, 'Tightening Screw' pointing to the central adjustment screw, 'Stock' pointing to the black handle, and 'Spirit Level Gauge' pointing to the vial on the handle.</p>	
Q23	<ol style="list-style-type: none"> <li>1. Keep the vehicle on level ground</li> <li>2. Jack up the vehicle at the certain height to make the wheel free to rotate</li> <li>3. Loosen the wheel nut and remove out the front wheel</li> <li>4. Extract brake drum with bearing from stub axle by using puller</li> <li>5. Remove the brakes pins/ bolts from strut bracket</li> <li>6. Remove the strut bracket bolts</li> <li>7. Remove support nuts by supporting the strut properly</li> <li>8. Dismount the strut assembly from the vehicle</li> <li>9. Use a spring compressor to remove the strut spring</li> <li>10. Fix the spring compressor on the strut and compress the spring</li> <li>11. To remove the spring support unit, loosen the nut slowly and release the spring compressor.</li> <li>12. Remove the spring from the strut</li> </ol>	[3]
Q24	<ol style="list-style-type: none"> <li>1. A grease nipple is provided on the slip joint for lubricating (greasing), but before greasing ensure that the parts are thoroughly cleaned,</li> <li>2. According to recommended interval by the manufacturer it should be lubricated (10000 km of run or yearly or once in a year)</li> </ol>	[3]
Q25	<ol style="list-style-type: none"> <li>1) More torque can be put through the shaft</li> <li>2) Can be used on longer Vehicles Without the whipping effect</li> </ol>	[3]

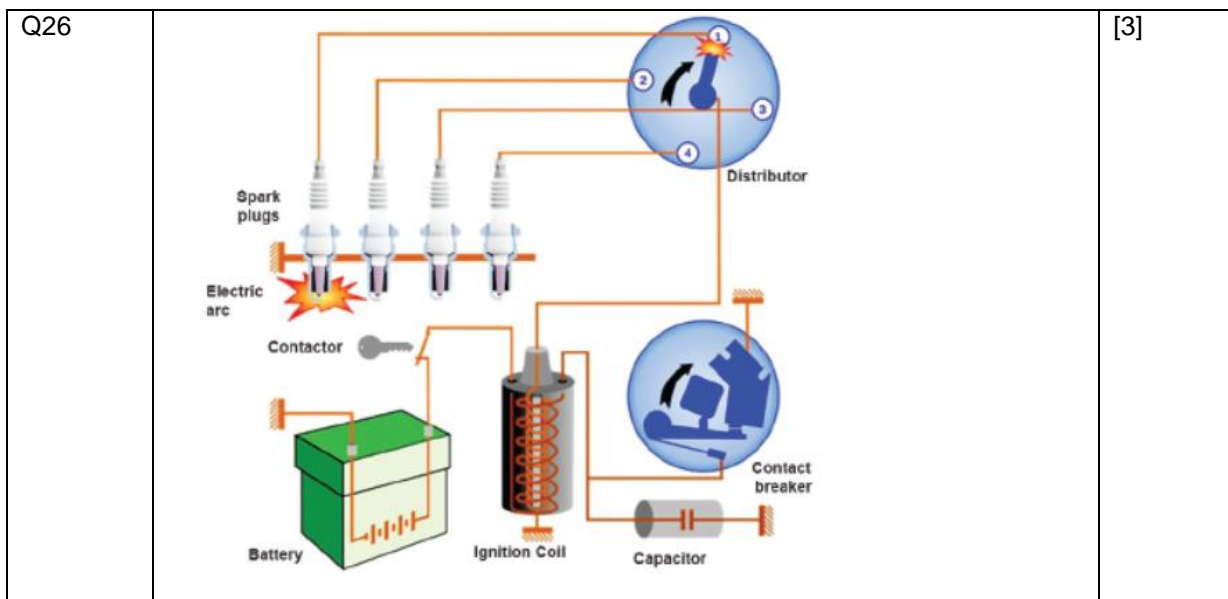

(Group D)

Question No.	Answers	Marks
Q27	<p>It is used as a measuring device to measure the accuracies in alignment, eccentricity of the parts/components.</p> <p>A dial gauge is like a fine watch. It consists of a graduated dial, pointer, plunger and a clamp. It measures the displacement of its plunger on a circular dial by means of a rotating point.</p> <div style="text-align: center;"> </div> <p>It works on the rack and pinion principal. The plunger has gear teeth cut on it and when it reciprocates it actuates a pinion attached to the pointer shaft. Thus any movement of the plunger causes a corresponding movement of the main pointer on a graduated dial.</p>	[3+2]

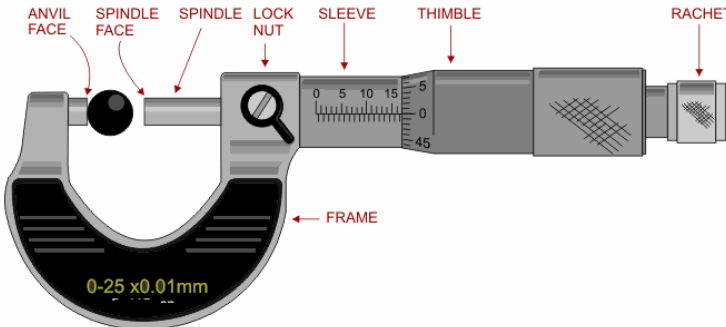
<p>Q28</p>	<p>Micrometer is a measuring instrument used to measure very fine and precise dimensions of length, width, thickness, diameter etc. Micrometer measure the cylindrical component like shaft, bolt, coin, boll etc. This is more accurate and precise than a vernier calliper.</p>  <p>Least Count = Pitch / Number of divisions on circular scale (thimble)</p>	<p>[2+3]</p>
------------	---	--------------

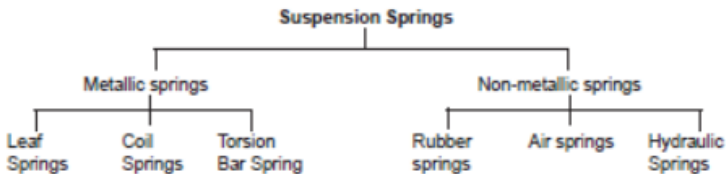
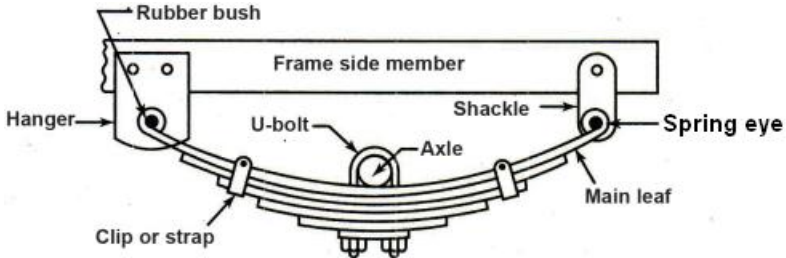
<p>Q29</p>	<p>The suspension springs are classified as follows:</p>  <p><b>Leaf Spring:</b> Leaf springs are made of a number of curved bands of spring steel called “leaves”, stacked together in order from shortest to longest. Stack of leaves is fastened together at the centre with a centre bolt or a rivet. To keep the leaves from slipping out of place, they are held at several places with clips. Both ends of the longest (main) leaf are bent to form spring eyes, used to attach the spring to the frame or structural member of a body.</p> <p>Generally, the longer a leaf spring, the softer it will be. Also, the more leaves in a leaf spring, the greater the load they will withstand. But on the other hand, the spring will become firmer and riding comfort will suffer.</p> 	<p>[2+3]</p>
------------	--	--------------

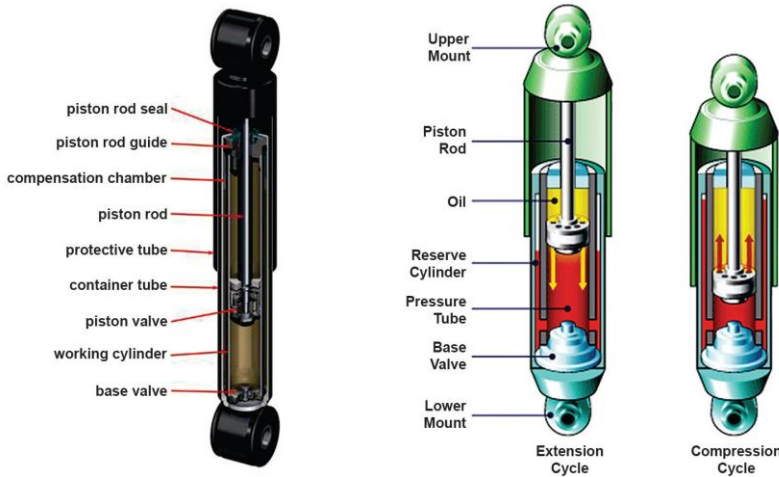
Q30		[5]
Q31	<p>A piston ring is a split ring that fits into a groove on the outer diameter of a piston in a reciprocating engine such as an internal combustion engine or steam engine.</p> <ol style="list-style-type: none"> <li>1. Sealing the combustion chamber so that there is no transfer of gases from the combustion chamber to the crank.</li> <li>2. Supporting heat transfer from the piston to the cylinder wall.</li> </ol> <p>Procedure for replacement of rings</p> <p>Replacing piston rings requires removing the pistons. To this effect, the cylinder head must be removed from the engine block, followed by the sump. After unscrewing the connecting rod ends, the pistons and the connecting rods can be removed from the top through the cylinder openings.</p> <p>When fitting new rings, have the pistons inspected and ensure that each piston ring is properly locked. Fitting the pistons equipped with new rings in the cylinders requires using a special tool called the piston ring compressor. When screwing the connecting rod to the crankshaft you should have the pans located there inspected.</p>	[5]